



The information in this documents is subject to change without notice and should not be construed as a commitment by ABB. ABB assumes no responsibility for any errors that may appear in this documents.

Except as may be expressly stated anywhere in this document, nothing herein shall be construed as any kind of guarantee or warranty by ABB for losses,damages to persons or property, fitness for a specific purpose or the like.

In no event shall ABB be liable for incidental or consequential damages arising from use of this document.

This document and parts thereof must not be reproduced or copied without ABB's written permission, and contents thereof must not be imparted to a third party nor be used for and unauthorized purpose.

Additional copies of this documents may be obtained from ABB at its then current charge.

© Copyright ABB All Right Reserved.

ABB China Ltd.Corp  
CNAUS Robotics  
SHANGHAI CHINA

We reserve all rights in this document and in the information contained therein. Reproduction, use or disclosure to third parties without express authority is strictly forbidden. Copyright ABB

Responsible Department: RARO/RD		Design by: Yan Zhang		IRT 710 & OmniCore V-line		ABB		ABB COPYRIGHT		Status: Approved		=	
Prepare by,Date: Yan Zhang 20240131		Approve by,Date:Fabrice Legeleux 202403		Replacement of		Replaced by				Document no. 3HAC091443-001		+ Rev.Ind Page 1	
												Total Page 37	



Description : IRT 710 & OmniCore V-line  
 Drawing number : 3HAC091443-001  
 Drawing version : 000  
 Date : 1/31/2024

Customer :  
 Year of construction :

Drawn by :  
 Number of pages : 37

We reserve all rights in this document and in the information contained therein. Reproduction, use or disclosure to third parties without express authority is strictly forbidden. Copyright ABB

Responsible Department: RARO/RD Design by: Yan Zhang		IRT 710 & OmniCore V-line		TITLE PAGE	Status: Approved	=	Rev.Ind	Page 2
Prepare by,Date: Yan Zhang 20240131	Approve by,Date: Fabrice Legeleux 202403				Replacement of	Replaced by		

# TABLE OF CONTENTS

PAGE	PAGE DESCRIPTION	Date	Edited by
1	ABB COPYRIGHT	4/20/2022	
2	TITLE PAGE	4/20/2022	
3	TABLE OF CONTENTS	3/18/2024	01
3.a	TABLE OF CONTENTS	3/18/2024	
4	BLOCK DIAGRAM CONNECTION for IRB57X0, IRB67X0, IRBX60, IRB7600 on IRT710	3/15/2024	
5	BLOCK DIAGRAM CONNECTION for IRB57X0, IRB67X0, IRB7600 on IRT710 (Spot welding)	3/15/2024	
6	BLOCK DIAGRAM CONNECTION for IRB460 or IRB4400 on IRT710	3/18/2024	
7	BLOCK DIAGRAM IRT MCB CONNECTION TRANSFER CARRIAGE	3/18/2024	
8	MOTOR IRT, IRB46x0/660/6xx0/760/7600/57x0/6650s --name to be update	3/18/2024	
9	MOTOR IRT, IRB4400, IRB460	12/7/2023	
10	MOTOR IRT, OPTION SERVO GUN	3/18/2024	
11	MOTOR IRT, TRANSFER CARRIAGE STATIC CABLE	12/7/2023	
12	MOTOR IRT, TRANSFER CARRIAGE SMB(6 Axes: 1-3 axes)	11/30/2023	
13	MOTOR IRT, TRANSFER CARRIAGE SMB (6 Axes: 4-6axes)	11/30/2023	
14	MOTOR IRT, TRANSFER CARRIAGE SMB (3 Axes)	12/7/2023	
15	MOTOR IRT, TRANSFER CARRIAGE MOTOR	12/13/2023	
16	MOTOR RESOLVER, IRB46x0/6xx0/760/7600	12/19/2023	
17	MOTOR RESOLVER STATIC CABLE	12/19/2023	
18	MOTOR RESOLVER, IRB4400	12/19/2023	
19	MOTOR RESOLVER, OPTION SERVO GUN	11/22/2023	
20	MOTOR RESOLVER CONNECTION	12/19/2023	
21	MOTOR RESOLVER, TRANSFER CARRIAGE STATIC CABLE	12/20/2023	
22	MOTOR RESOLVER, TRANSFER CARRIAGE SMB 1(6Axes)	11/24/2023	
23	MOTOR RESOLVER, TRANSFER CARRIAGE MOTOR	2/1/2024	
24	OPTION LUBRICATION POWER IRT	3/18/2024	
25	OPTION LUBRICATION FEEDBACK IRT	3/18/2024	
26	OPTION LUBRICATION POWER TRANSFER CARRIAGE	3/18/2024	
27	OPTION LUBRICATION FEEDBACK TRANSFER CARRIAGE	3/18/2024	
28	MOTOR CABLE, IRB4400	2/1/2024	
29	MOTOR CABLE, IRB4400	2/1/2024	
30	MOTOR CABLE, IRB460/760/4400/4600/6xx0/7600	2/1/2024	
31	RESOLVER CABLE, IRB460/760/4600/6xx0/7600	2/1/2024	
32	OPTION CUSTOMER POWER/SIGNAL, IRB4400	2/1/2024	

We reserve all rights in this document and its content. All information contained herein is confidential and its disclosure to third parties without express authority is strictly forbidden. © Copyright 2003 ABB

Latest revision:			Lab/Office:	IRT 710 & OmniCore V-line	Status:	Plant: =
				TABLE OF CONTENTS	APPROVED	Location: +
Prepared by, date: Yan ZHANG 20240131		Approved by, date: Fabrice Legeleux 20240320		Document no.	3HAC091443-001	Rev. Ind Page 3
					000	Next 3.a
						Total 37



\* SYSTEM CONFIGURATION

MOTOR No.	SMB NODE No.	UNIT
M7	7	IRB

IRB4600, 67X0, 57X0, 6650S, 7600, X60

V250XT/V400XT

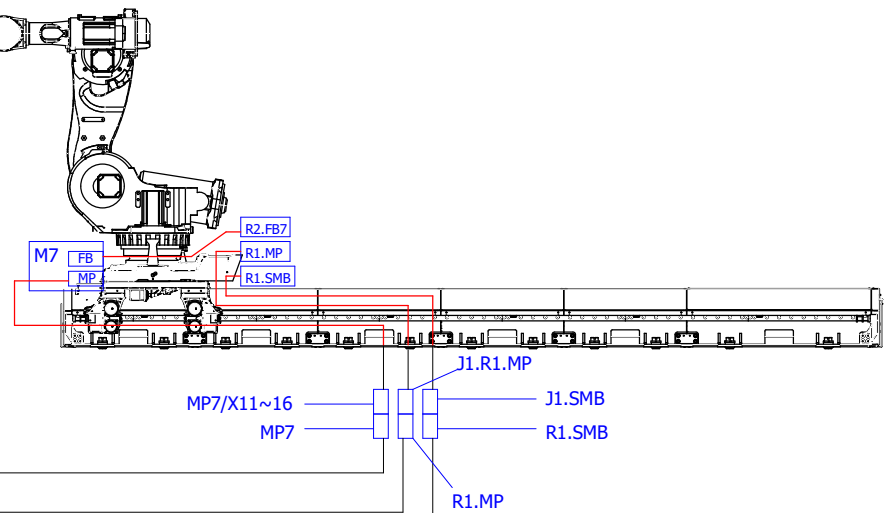
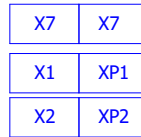

3.a

5

Responsible Department: RARO/RD		Design by: Yan Zhang		IRT 710 & OmniCore V-line		Status: Approved		=			
Prepare by, Date: Yan Zhang 20240131		Approve by, Date: Fabrice Legeleux 202403		Replacement of		Replaced by		+			
ABB						BLOCK DIAGRAM CONNECTION for IRB57X0, IRB67X0, IRB60, IRB7600 on IRT710		Document no. 3HAC091443-001			
								Rev.Ind		Page 4	
										Total Page 37	

We reserve all rights in this document and in the information contained therein. Reproduction, use or disclosure to third parties without express authority is strictly forbidden. Copyright ABB

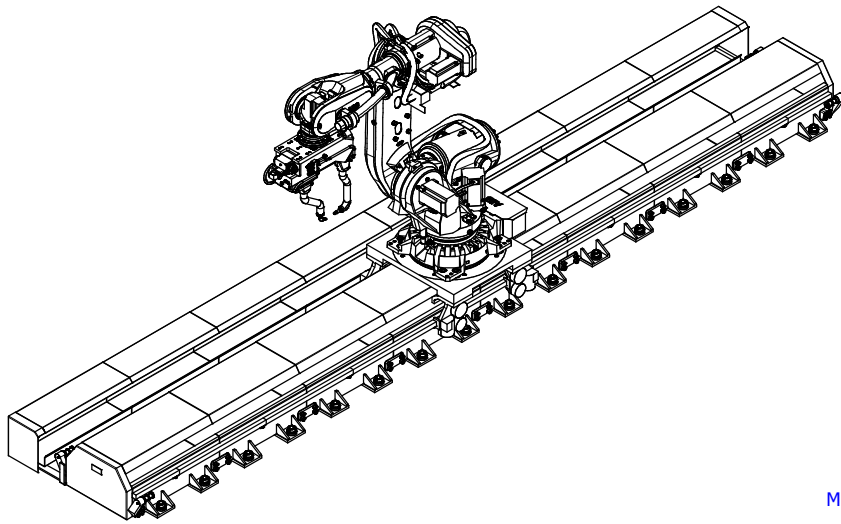

\* SYSTEM CONFIGURATION

MOTOR No.	SMB NODE No.	UNIT
M7	1	MCB
SW motor	7	IRB

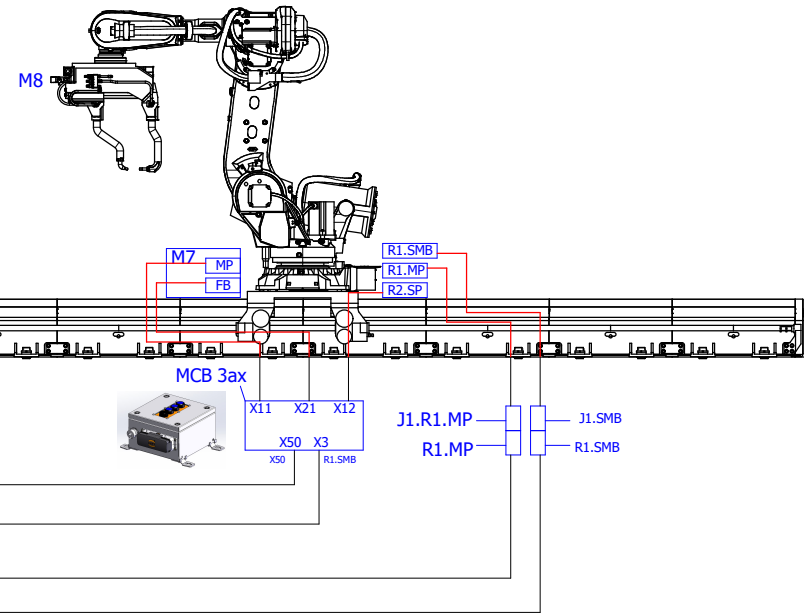

V250XT/V400XT



X7	X7/X8
X3	XP2
X1	XP1
X2	XP2

Responsible Department: RARO/RD	Design by: Yan Zhang
Prepare by, Date: Yan Zhang 20240131	Approve by, Date: Fabrice Legeleux 202403

IRT 710 & OmniCore V-line	Replacement of	Replaced by
---------------------------	----------------	-------------



BLOCK DIAGRAM  
CONNECTION for IRB57X0, IRB67X0,  
IRB7600 on IRT710 (Spot welding)

Status:  
**Approved**  
Document no.  
**3HAC091443-001**

Rev.Ind	Page
+	5
	Total Page
	37

\* SYSTEM CONFIGURATION

MOTOR No.	SMB NODE No.	UNIT
M7	1	MCB

V250XT/V400XT



X7	X7/X8
X3	XP2
X1	XP1
X2	XP2

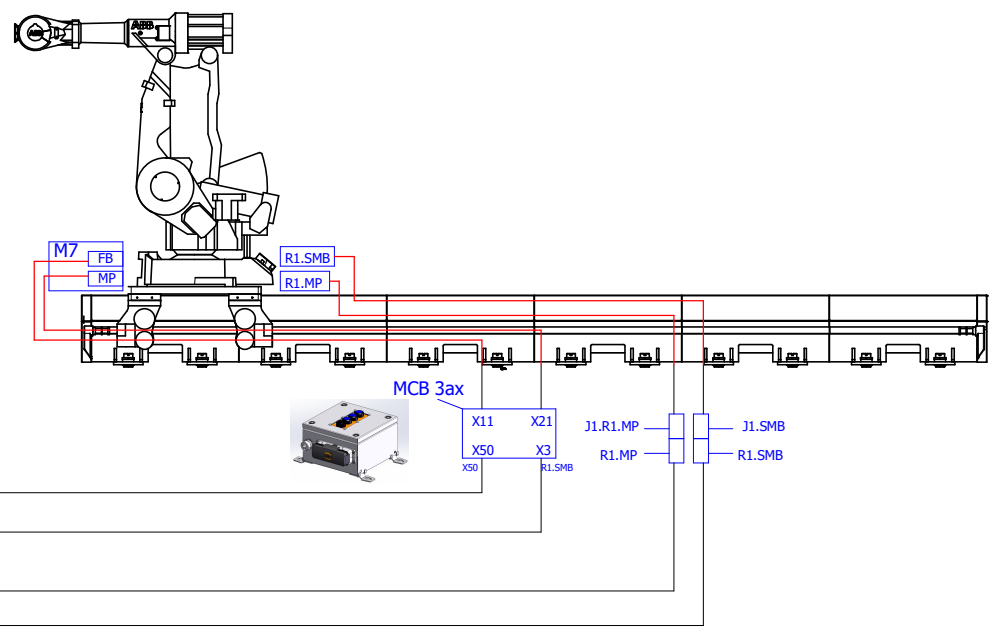

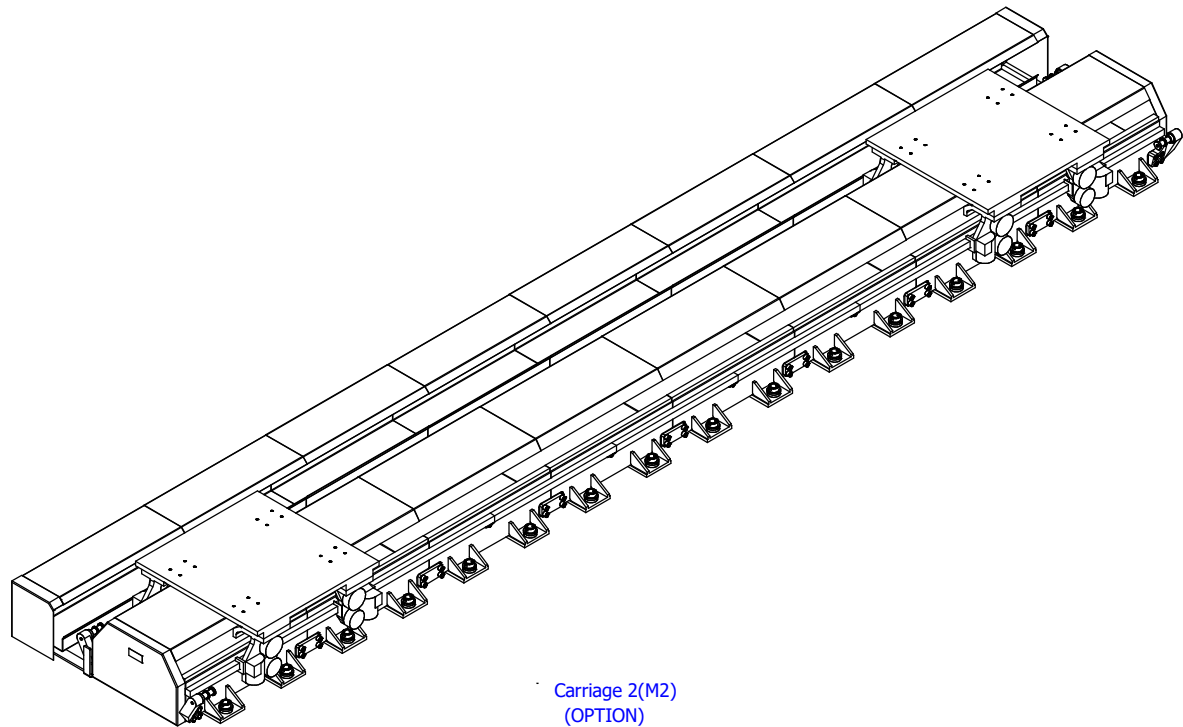

\* SYSTEM CONFIGURATION

MOTOR No.	SMB NODE No.	UNIT
M1	1	MCB-6ax
M2(OPTION)	2	MCB-6ax

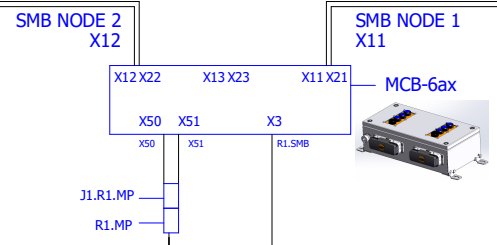
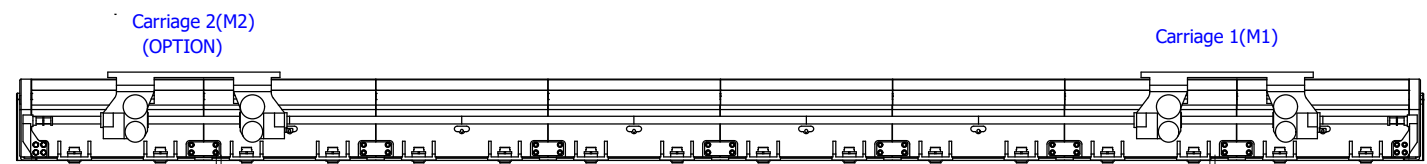



We reserve all rights in this document and in the information contained therein. Reproduction, use or disclosure to third parties without express authority is strictly forbidden. Copyright ABB

SEE EL. DRAWINGS FOR THE  
ROBOT CONTROL SYSTEM

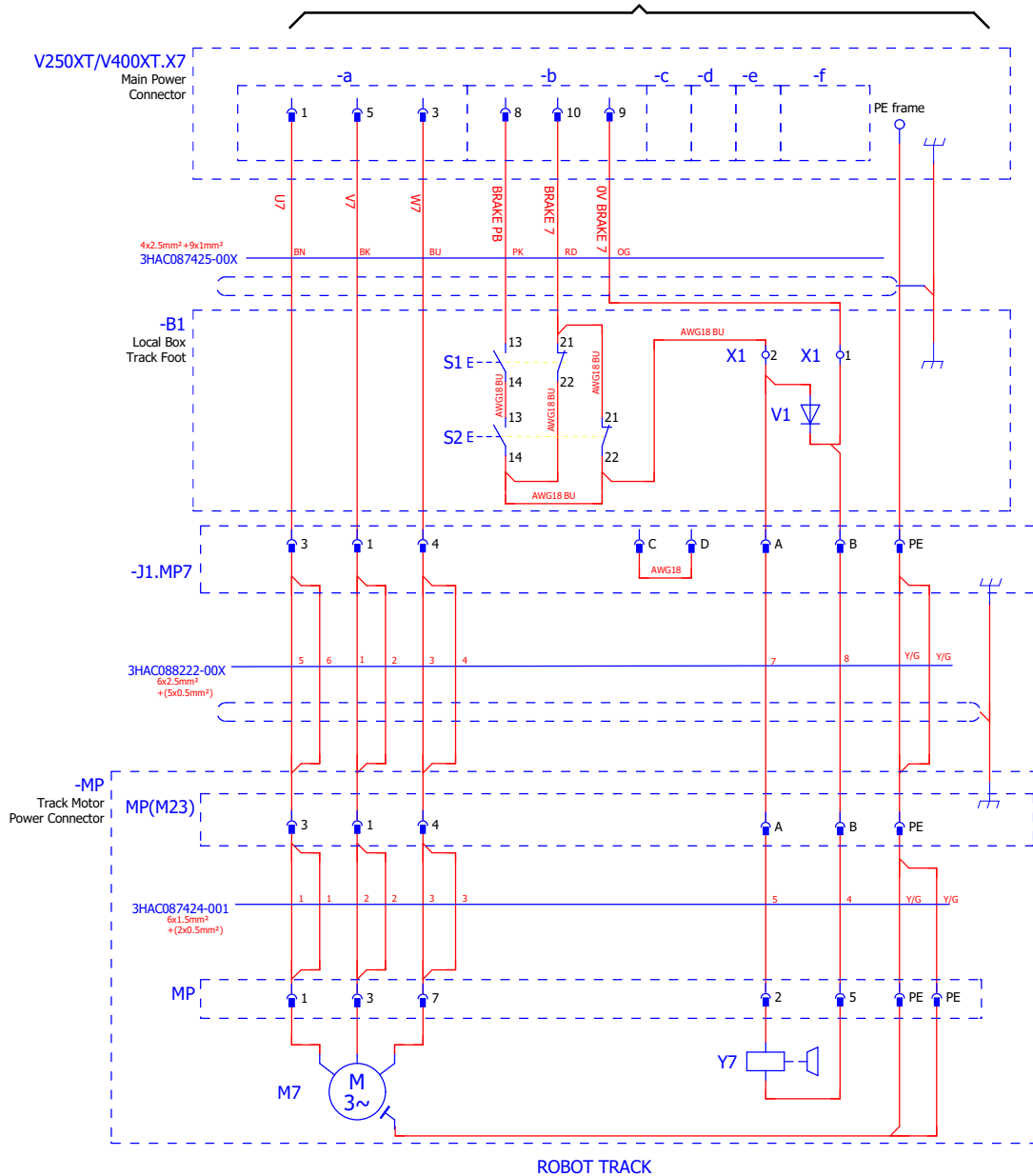

7

9

Responsible Department:	RARO/RD	Design by:	Yan Zhang
Prepare by, Date:	Yan Zhang 20240131	Approve by, Date:	Fabrice Legeleux 202403

IRT 710 & OmniCore V-line	Replacement of	Replaced by
---------------------------	----------------	-------------



MOTOR IRT,  
IRB46x0/660/6xx0/760/7600/57x0/6650s  
--name to be update

Status:  
Approved  
Document no.  
3HAC091443-001

Rev.Ind	Page
8	8
Total Page	37

SEE EL. DRAWINGS FOR THE  
ROBOT CONTROL SYSTEM

V250XT/V400XT.X7/X8  
Main Power Connector

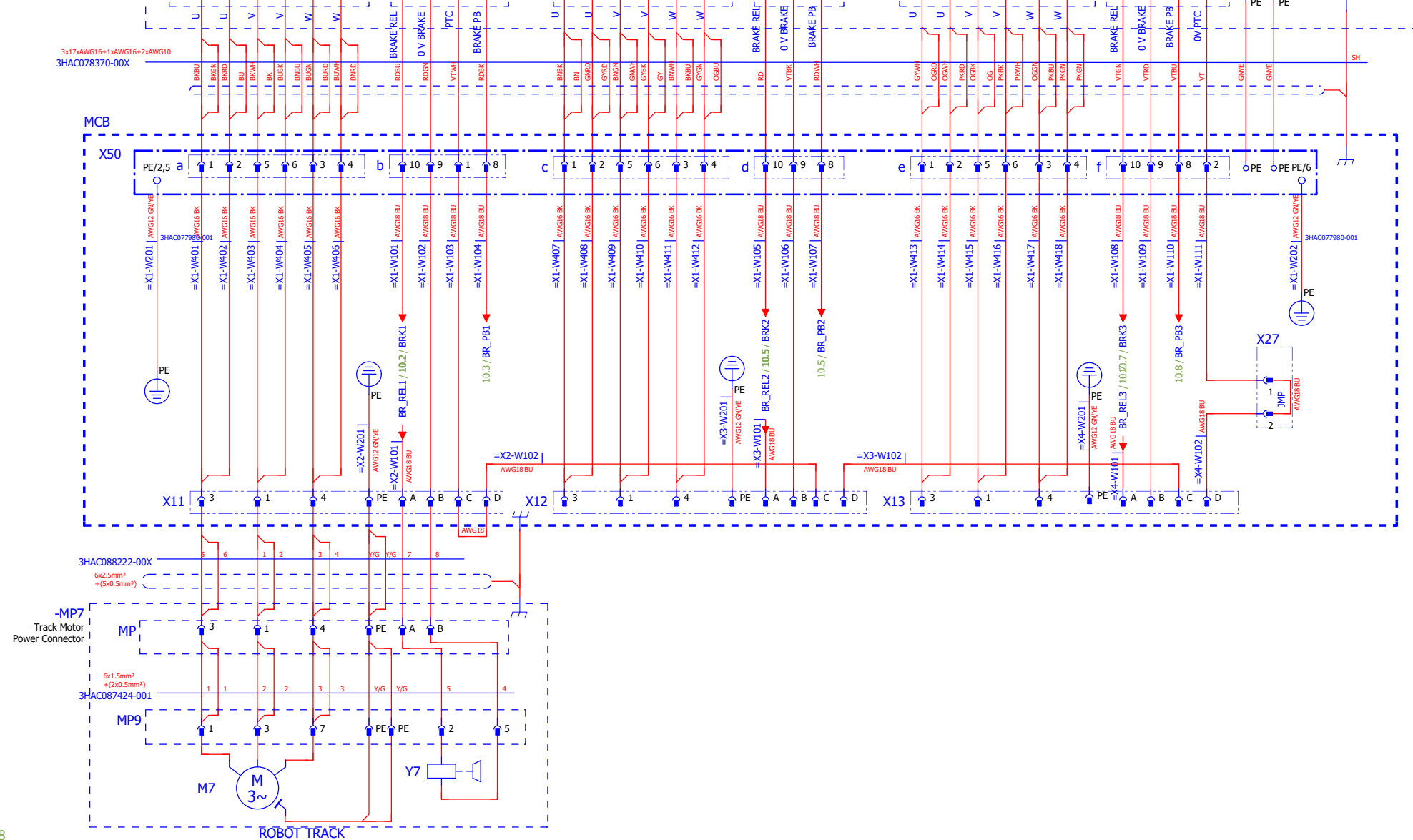

8 ROBOT TRACK

Responsible Department: RARO/RD Design by: Yan Zhang  
Prepare by, Date: Yan Zhang 20240131 Approve by, Date: Fabrice Legeleux 202403 Replacement of Replaced by

IRT 710 & OmniCore V-line



MOTOR IRT, IRB4400, IRB460

Status: Approved  
Document no. 3HAC091443-001

Rev.Ind Page 9  
Total Page 37

We reserve all rights in this document and in the information contained therein. Reproduction, use or disclosure to third parties without express authority is strictly forbidden. Copyright ABB

SEE EL. DRAWINGS FOR THE  
ROBOT CONTROL SYSTEM

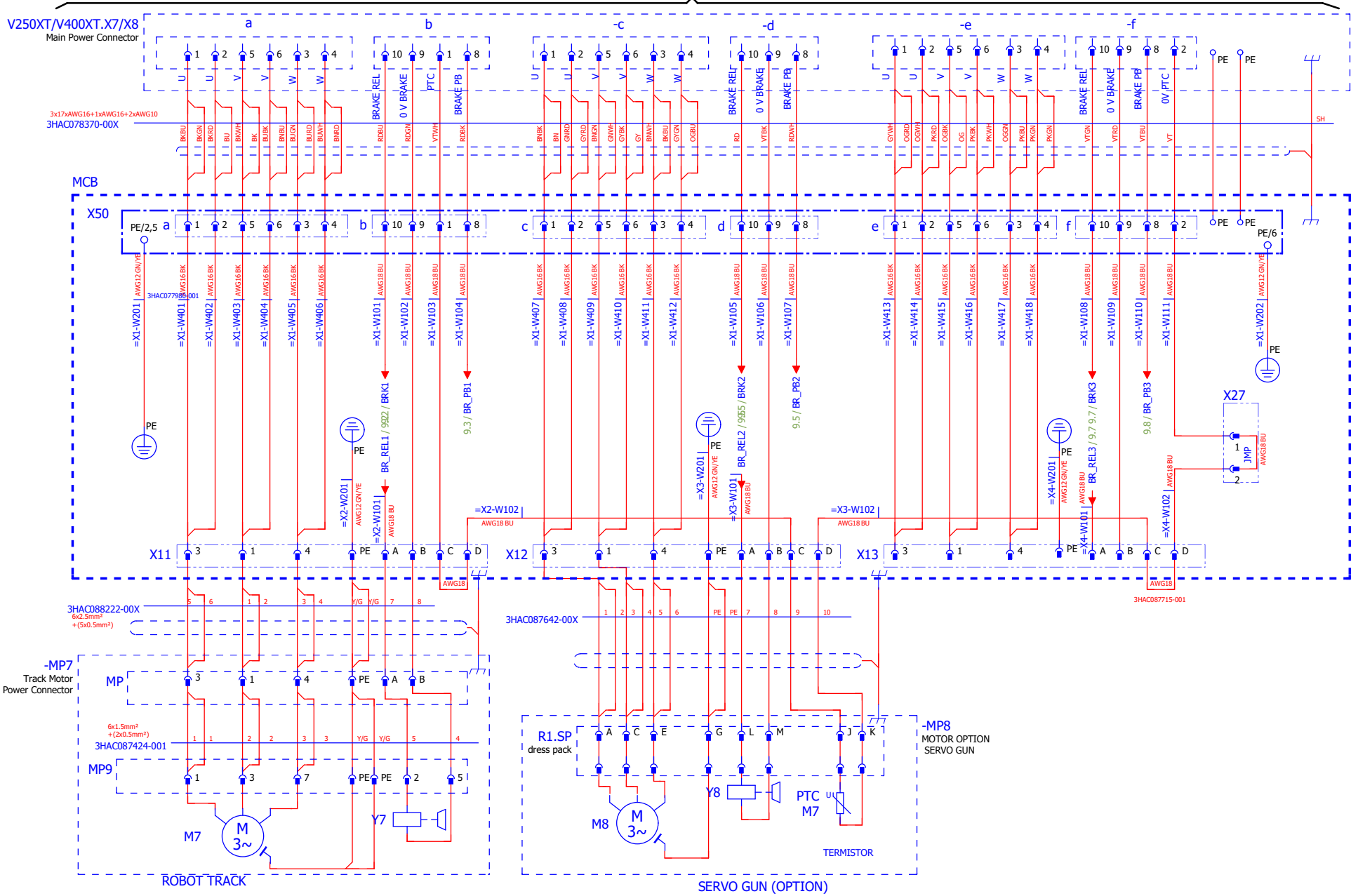

We reserve all rights in this document and in the information contained therein. Reproduction, use or disclosure to third parties without express authority is strictly forbidden. Copyright ABB

9

Responsible Department:	RARO/RD	Design by:	Yan Zhang
Prepare by, Date:	Yan Zhang 20240131	Approve by, Date:	Fabrice Legeleux 202403

IRT 710 & OmniCore V-line	
Replacement of	Replaced by



MOTOR IRT, OPTION SERVO GUN

Status:	Approved
Document no.	3HAC091443-001
Rev.Ind	Page 10
	Total Page 37

SEE EL. DRAWINGS FOR THE ROBOT CONTROL SYSTEM

Omnicores V250XT/V400XT.X1

Main Power Connector V250XT/V400XT X1 High Voltage

We reserve all rights in this document and in the information contained therein. Reproduction, use or disclosure to third parties without express authority is strictly forbidden. Copyright ABB

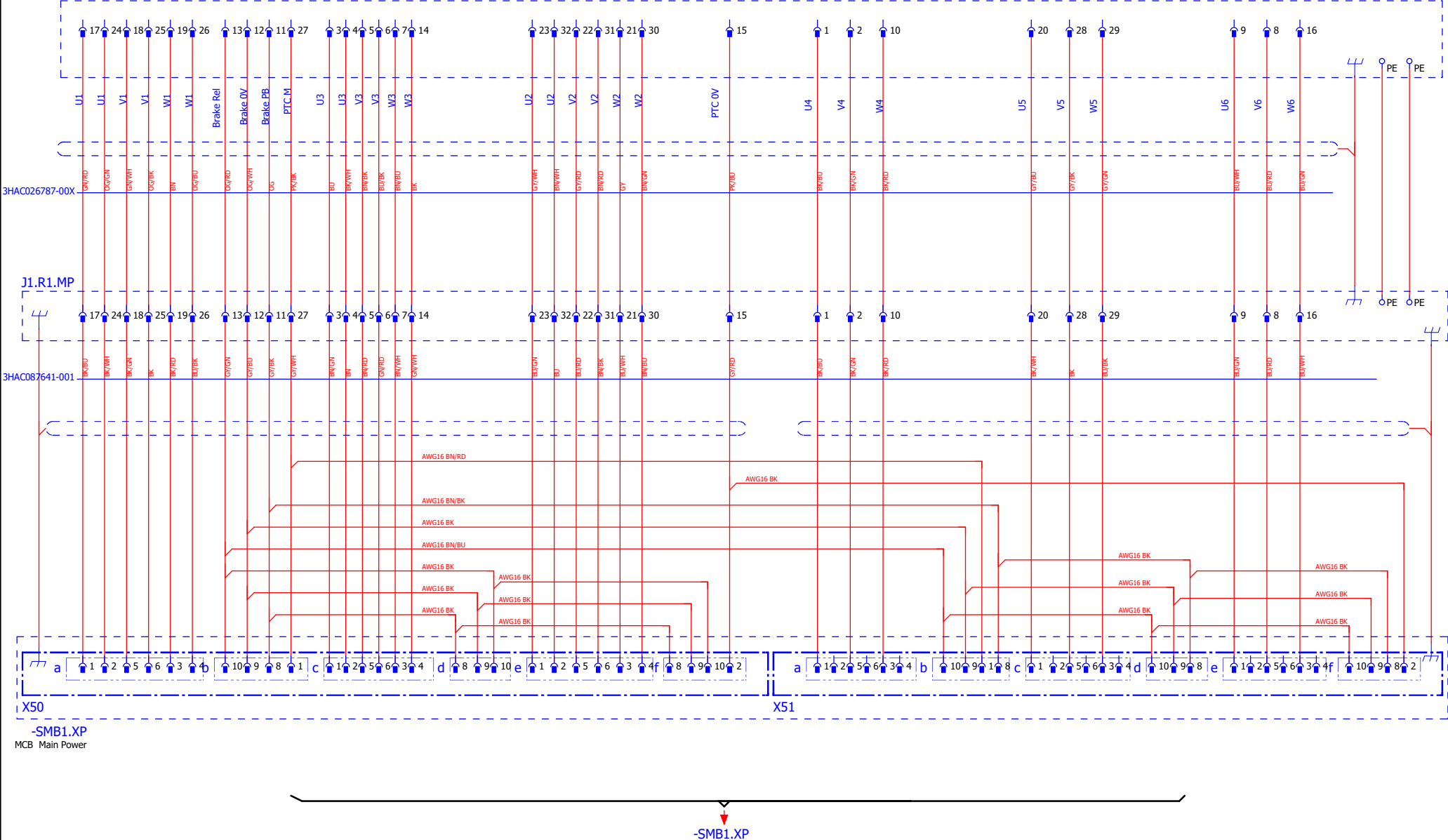

Responsible Department:	RARO/RD	Design by:	Yan Zhang
Prepare by, Date:	Yan Zhang 20240131	Approve by, Date:	Fabrice Legeleux 202403

IRT 710 & OmniCore V-line
Replacement of
Replaced by



MOTOR IRT, TRANSFER CARRIAGE  
STATIC CABLE

Status:  
Approved  
Document no.  
3HAC091443-001

Rev.Ind	Page	11
	Total Page	37

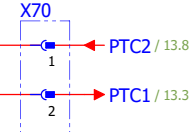
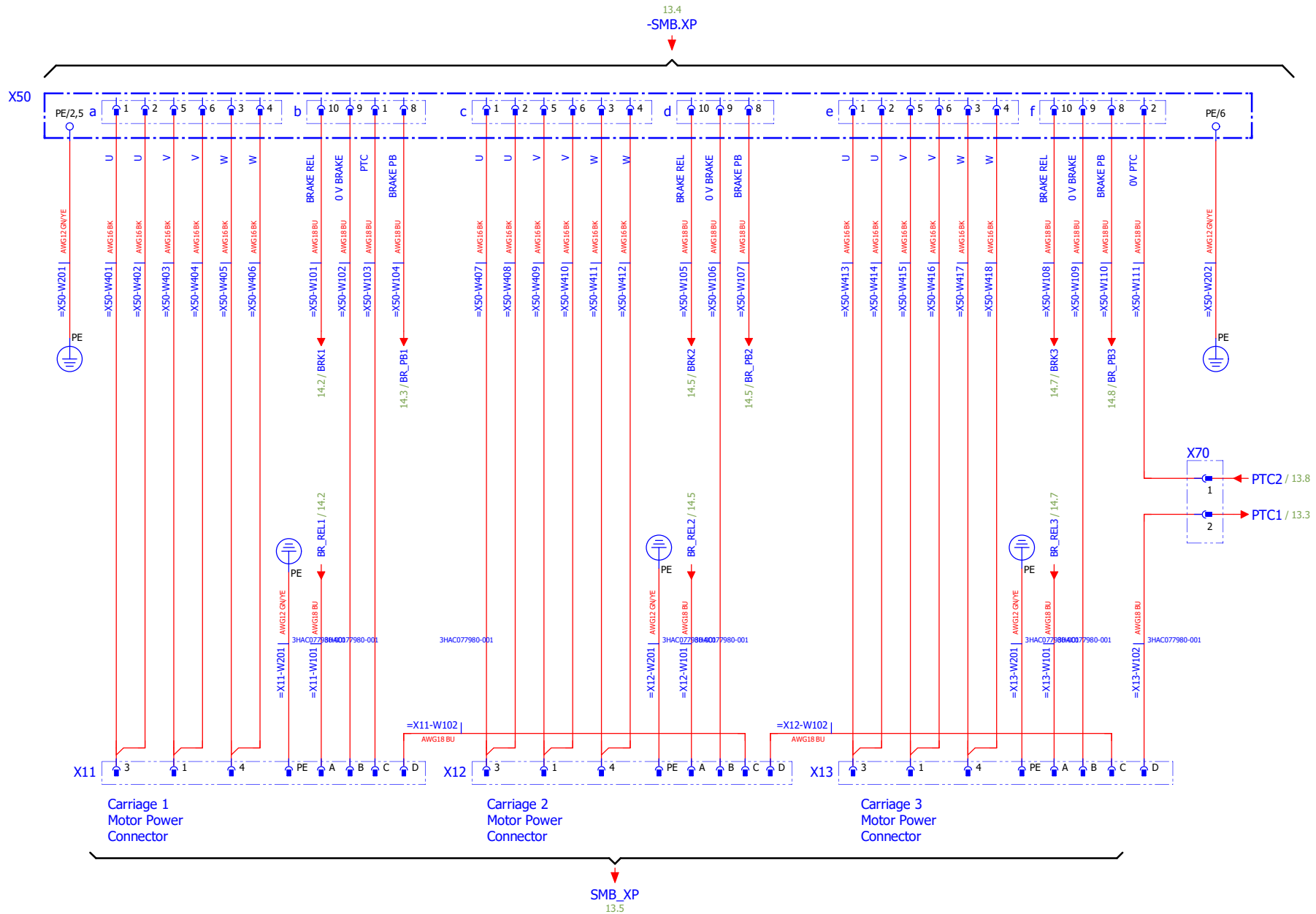

Carriage 1  
Motor Power  
Connector

Carriage 2  
Motor Power  
Connector

Carriage 3  
Motor Power  
Connector

Responsible Department: RARO/RD	Design by: Yan Zhang	IRT 710 & OmniCore V-line	<b>ABB</b>	Status: Approved	=
Prepare by, Date: Yan Zhang 20240131	Approve by, Date: Fabrice Legeleux 202403	Replacement of	Replaced by	MOTOR IRT, TRANSFER CARRIAGE SMB(6 Axes: 1-3 axes)	+
				Document no. 3HAC091443-001	Rev.Ind
					Page 12
					Total Page 37

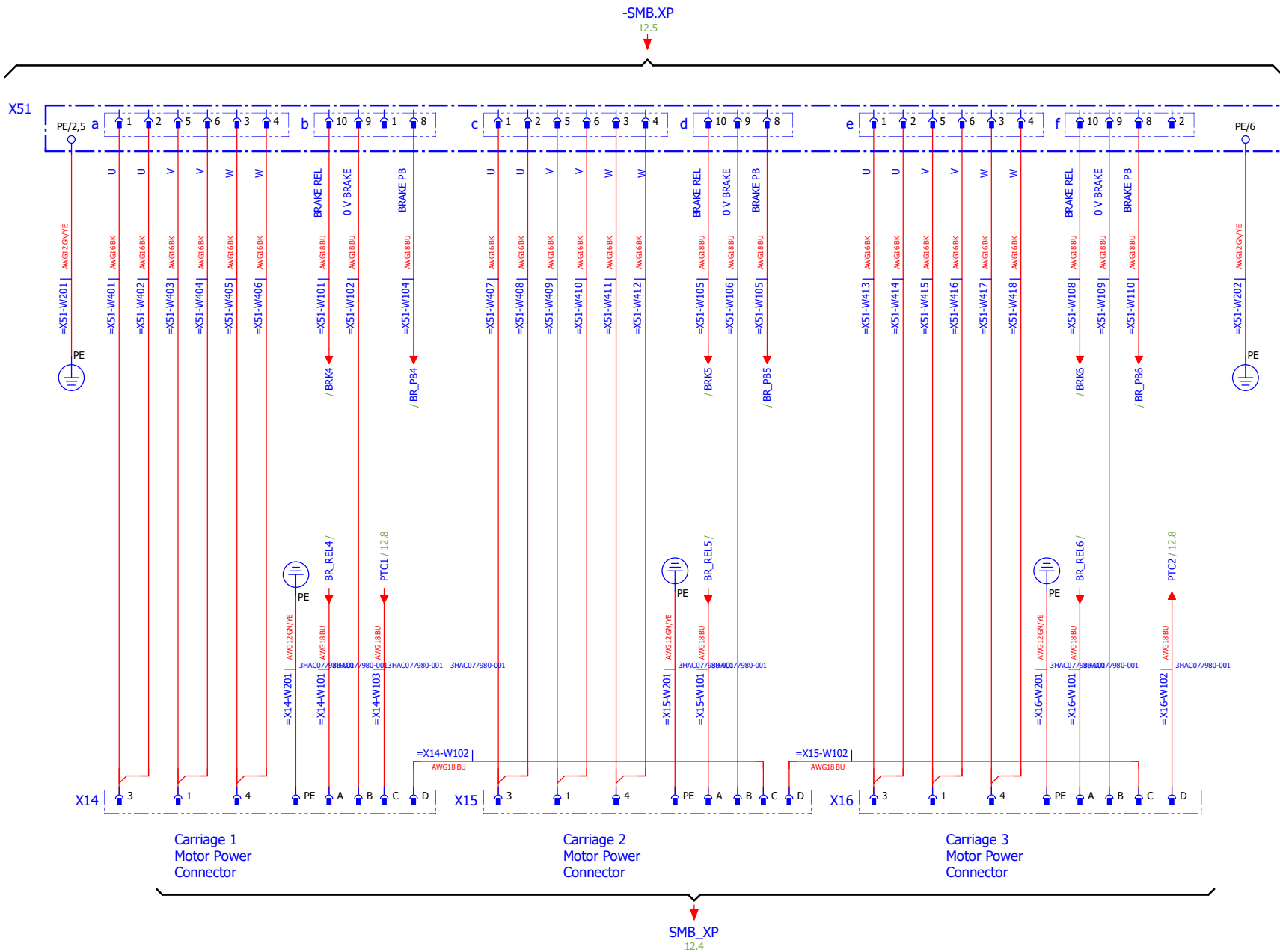

Responsible Department: RARO/RD	Design by: Yan Zhang
Prepare by, Date: Yan Zhang 20240131	Approve by, Date: Fabrice Legeleux 202403

Replacement of	Replaced by
----------------	-------------



MOTOR IRT, TRANSFER CARRIAGE SMB  
(6 Axes: 4-6axes)

Status: Approved	=
Document no. 3HAC091443-001	+

Rev.Ind	Page 13
	Total Page 37

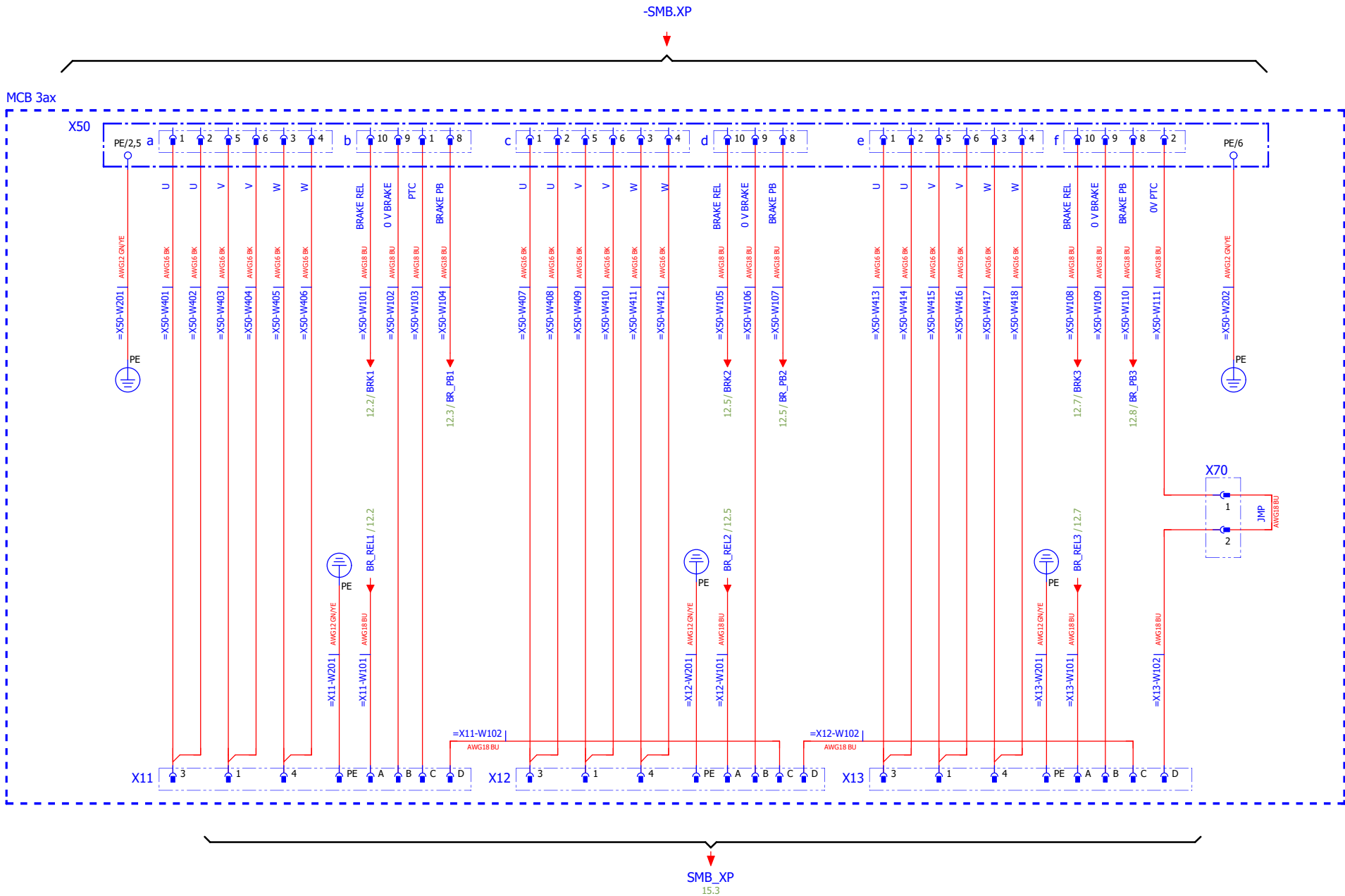

We reserve all rights in this document and in the information contained therein. Reproduction, use or disclosure to third parties without express authority is strictly forbidden. Copyright ABB

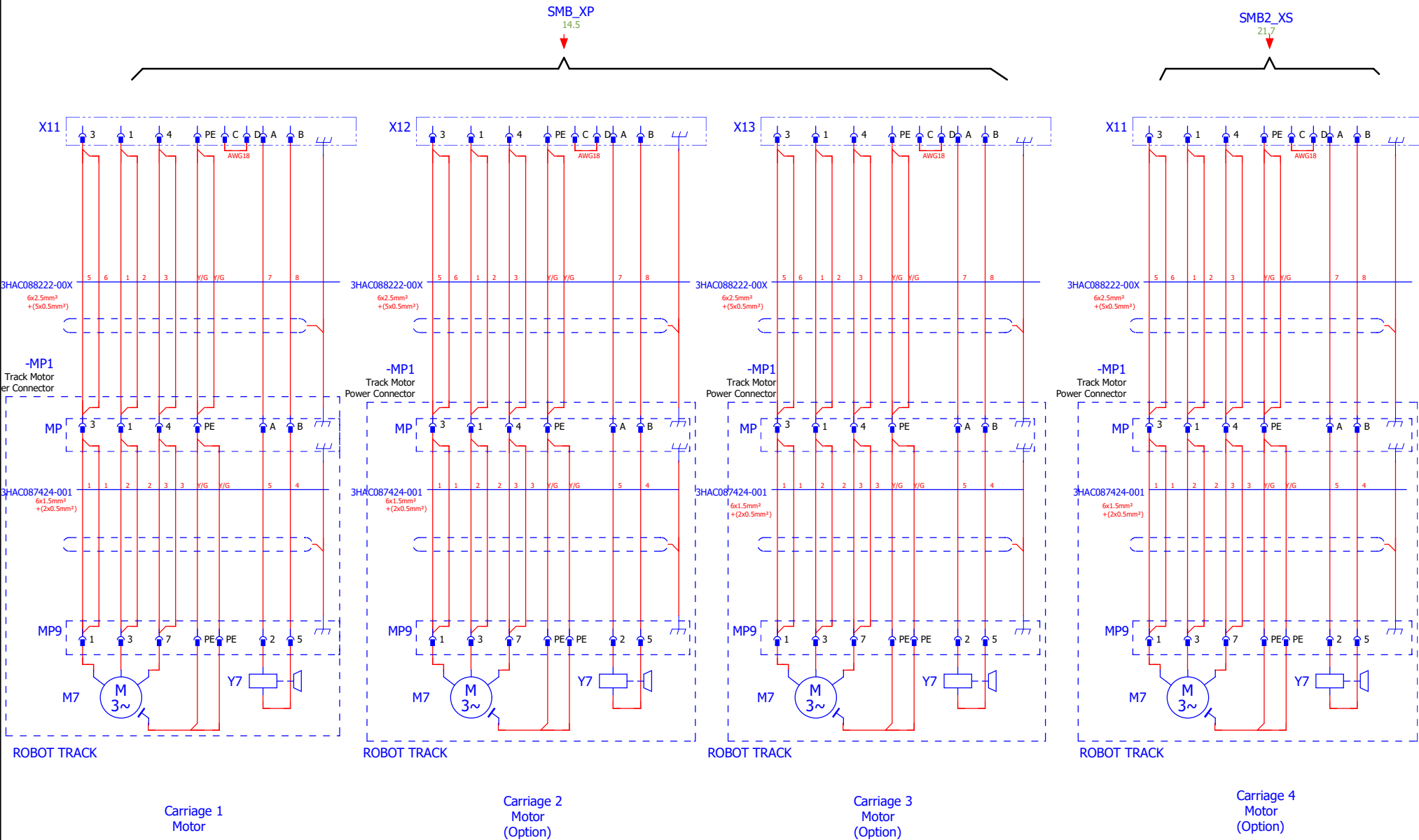

Responsible Department: RARO/RD		Design by: Yan Zhang		IRT 710 & OmniCore V-line		Status: Approved			
Prepare by, Date: Yan Zhang 20240131		Approve by, Date: Fabrice Legeleux 202403		Replacement of		Replaced by		Rev.Ind	
						MOTOR IRT, TRANSFER CARRIAGE MOTOR		Document no. 3HAC091443-001	
								Page 15	
								Total Page 37	





SEE EL. DRAWINGS FOR THE  
ROBOT MANIPULATOR SYSTEM

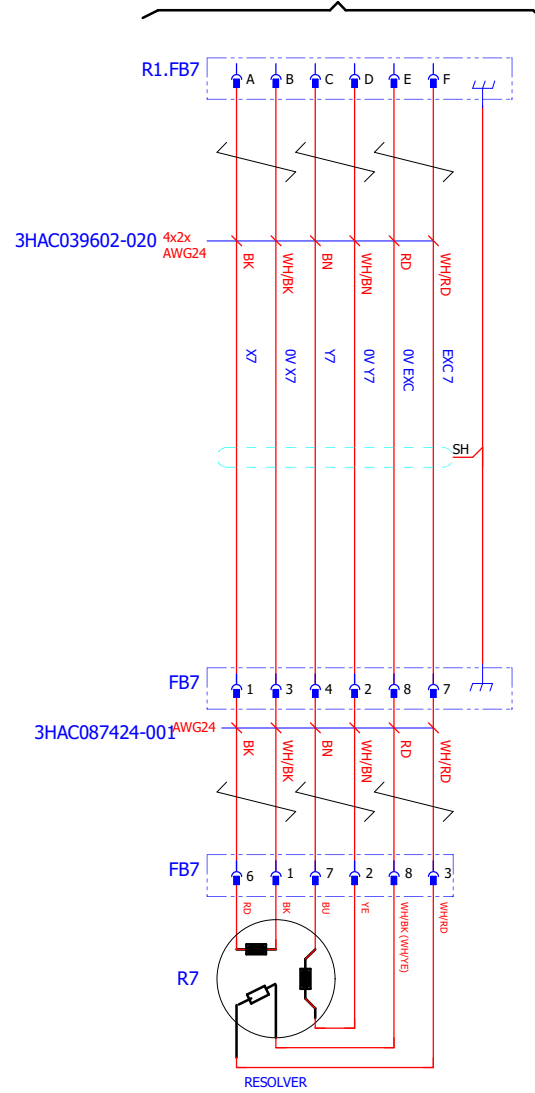

Responsible Department:	RARO/RD	Design by:	Yan Zhang
Prepare by, Date:	Yan Zhang 20240131	Approve by, Date:	Fabrice Legeleux 20240324

Replacement of	IRT 710 & OmniCore V-line	Replaced by
----------------	---------------------------	-------------



MOTOR RESOLVER,  
IRB46x0/6xx0/760/7600

Status:  
**Approved**  
Document no.  
**3HAC091443-001**

Rev.Ind	Page
+	16
Total Page 37	

SEE EL. DRAWINGS FOR THE  
ROBOT CONTROL SYSTEM

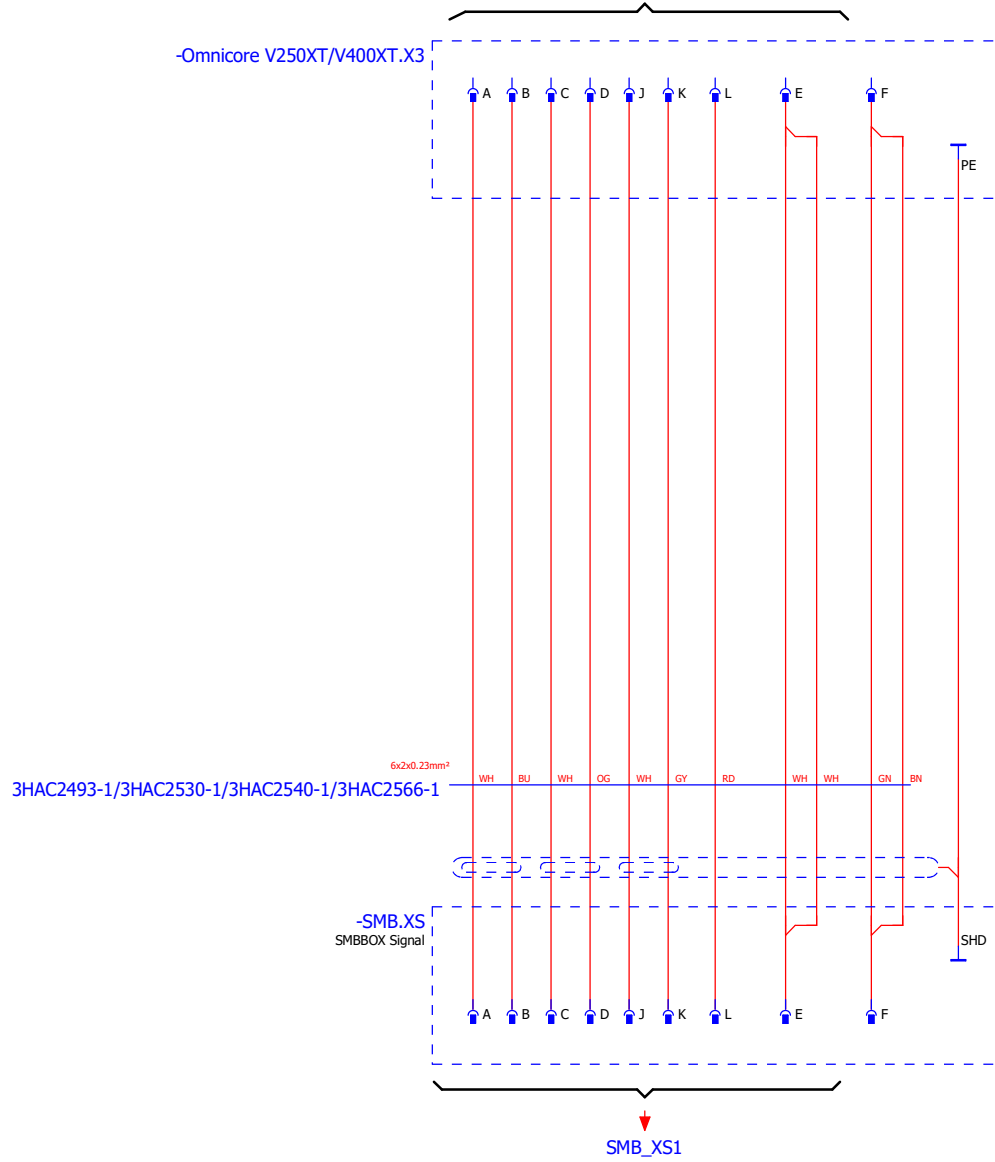

Responsible Department: RARO/RD	Design by: Yan Zhang
Prepare by, Date: Yan Zhang 20240131	Approve by, Date: Fabrice Legeleux 202403

IRT 710 & OmniCore V-line	Replacement of	Replaced by
---------------------------	----------------	-------------



MOTOR RESOLVER STATIC CABLE

Status: Approved	=
Document no. 3HAC091443-001	+

Rev.Ind	Page 17
	Total Page 37

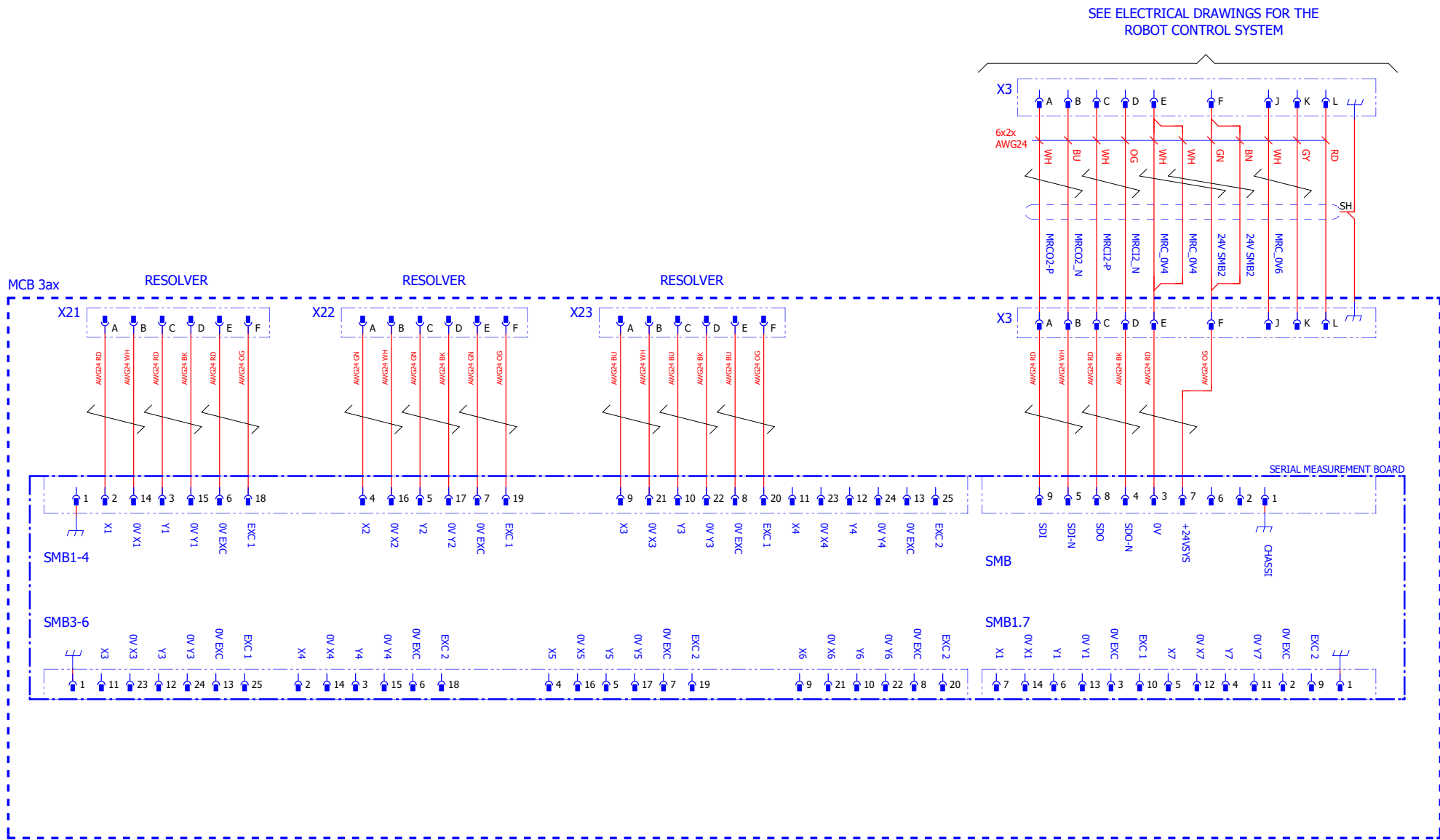

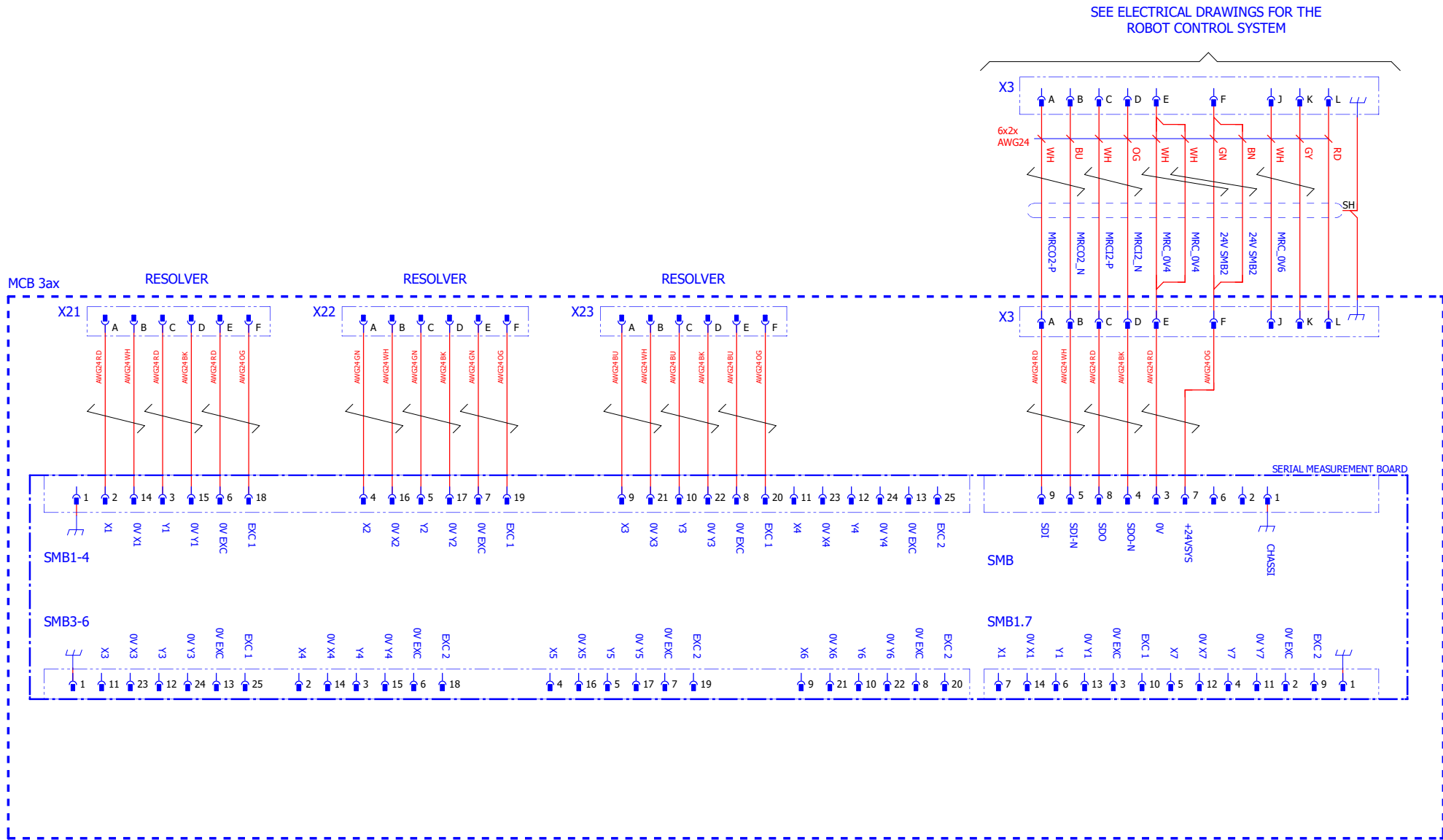

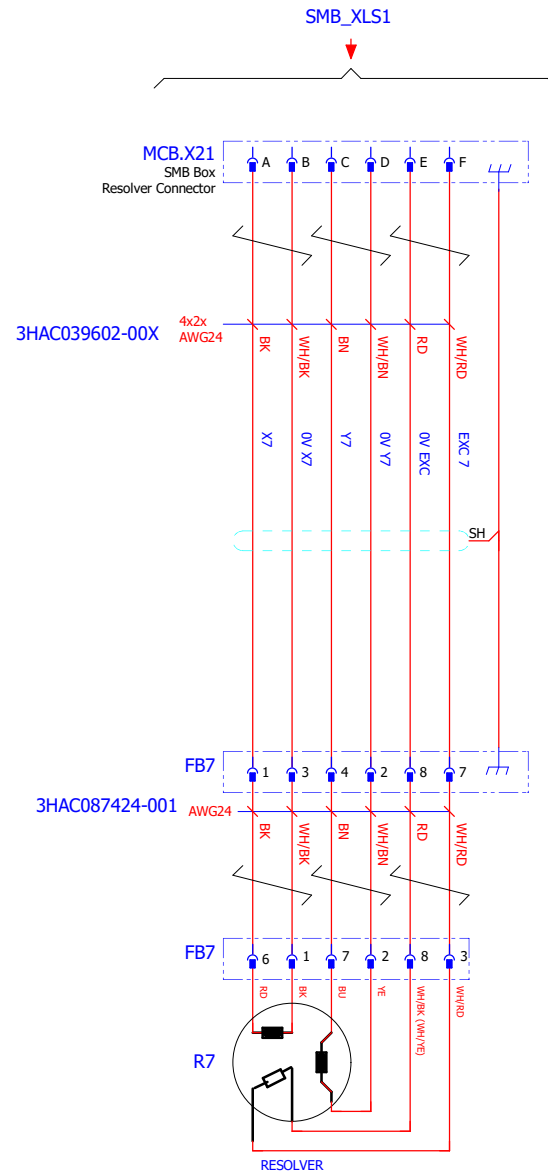

Responsible Department:	RARO/RD	Design by:	Yan Zhang
Prepare by, Date:	Yan Zhang 20240131	Approve by, Date:	Fabrice Legeleux 202403

IRT 710 & OmniCore V-line	Replacement of	Replaced by
---------------------------	----------------	-------------



MOTOR RESOLVER CONNECTION

Status:	Approved
Document no.	3HAC091443-001

Rev.Ind	Page	20
	Total Page	37

We reserve all rights in this document and in the information contained therein. Reproduction, use or disclosure to third parties without express authority is strictly forbidden. Copyright ABB

SEE EL. DRAWINGS FOR THE ROBOT CONTROL SYSTEM

SEE EL. DRAWINGS FOR THE ROBOT CONTROL SYSTEM

-Omnicores V250XT/V400XT.X2

-Omnicores V250XT/V400XT.X3

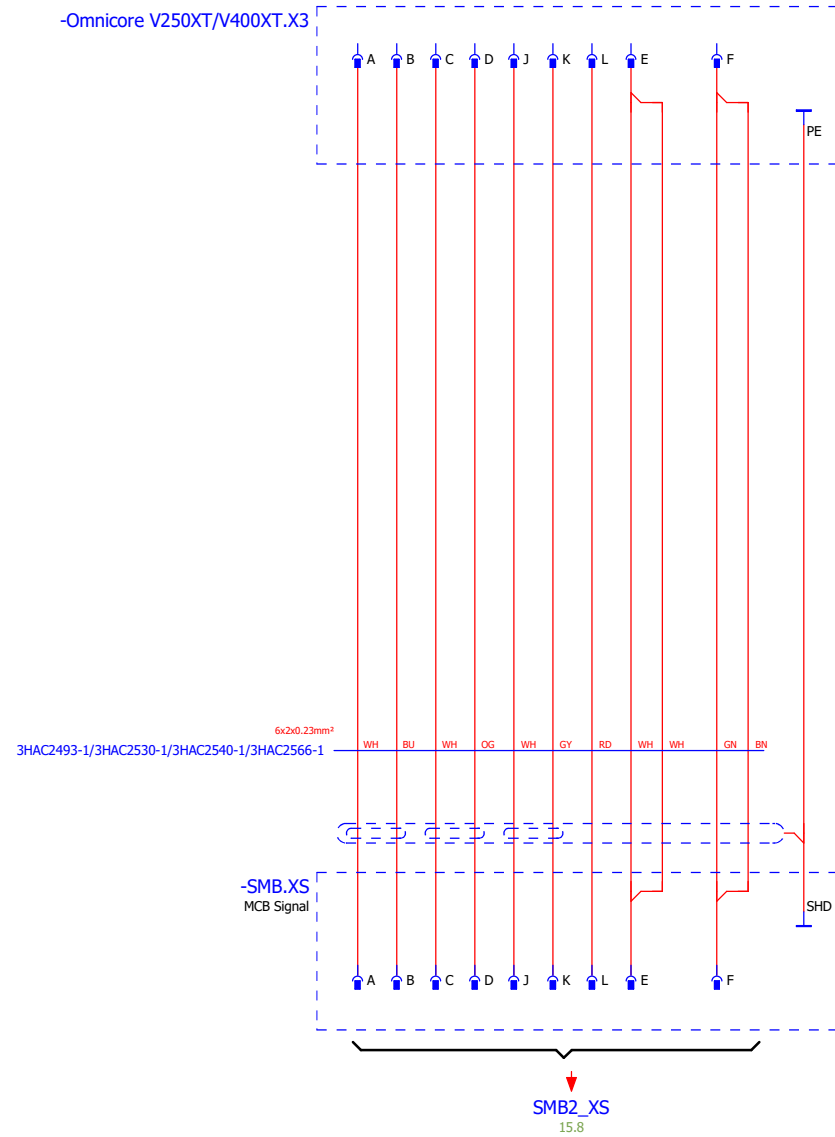
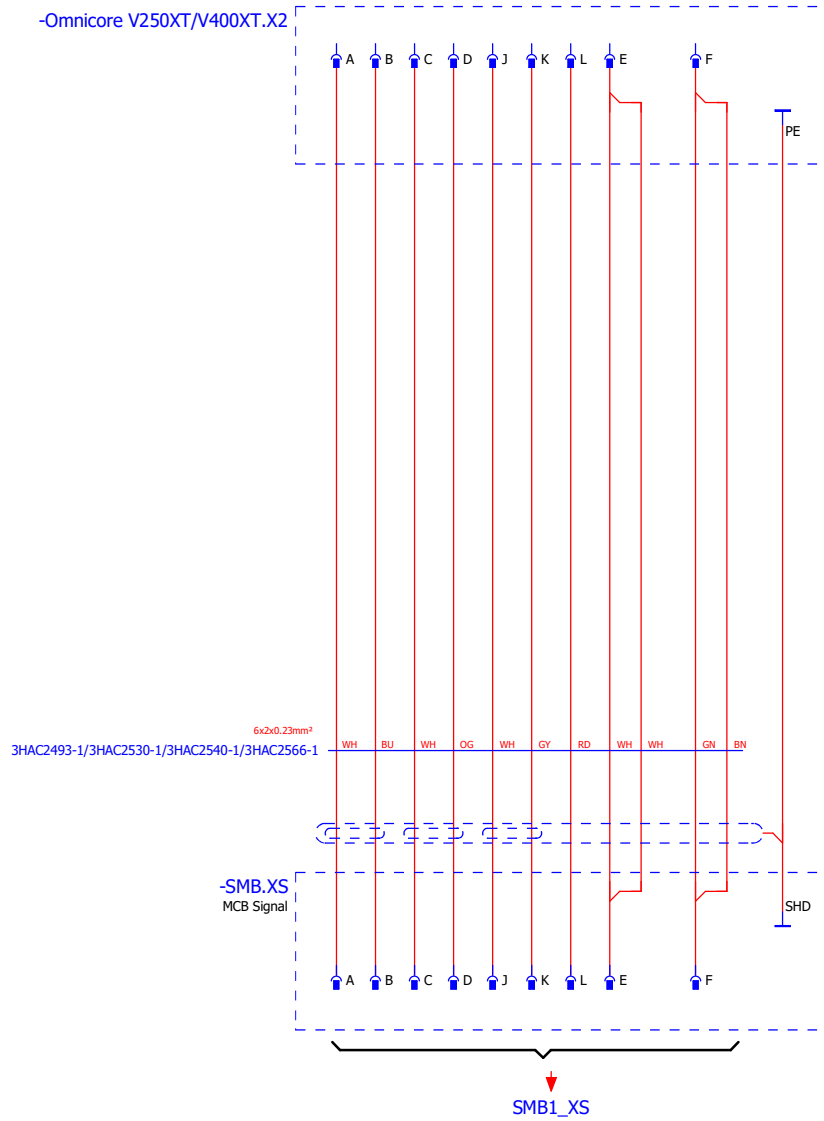

Responsible Department:	RARO/RD	Design by:	Yan Zhang
Prepare by, Date:	Yan Zhang 20240131	Approve by, Date:	Fabrice Legeleux 202403

IRT 710 & OmniCore V-line	Replacement of	Replaced by
---------------------------	----------------	-------------



MOTOR RESOLVER, TRANSFER CARRIAGE STATIC CABLE

Status: Approved  
Document no. 3HAC091443-001

Rev.Ind	Page
21	37
Total Page	

We reserve all rights in this document and in the information contained therein. Reproduction, use or disclosure to third parties without express authority is strictly forbidden. Copyright ABB

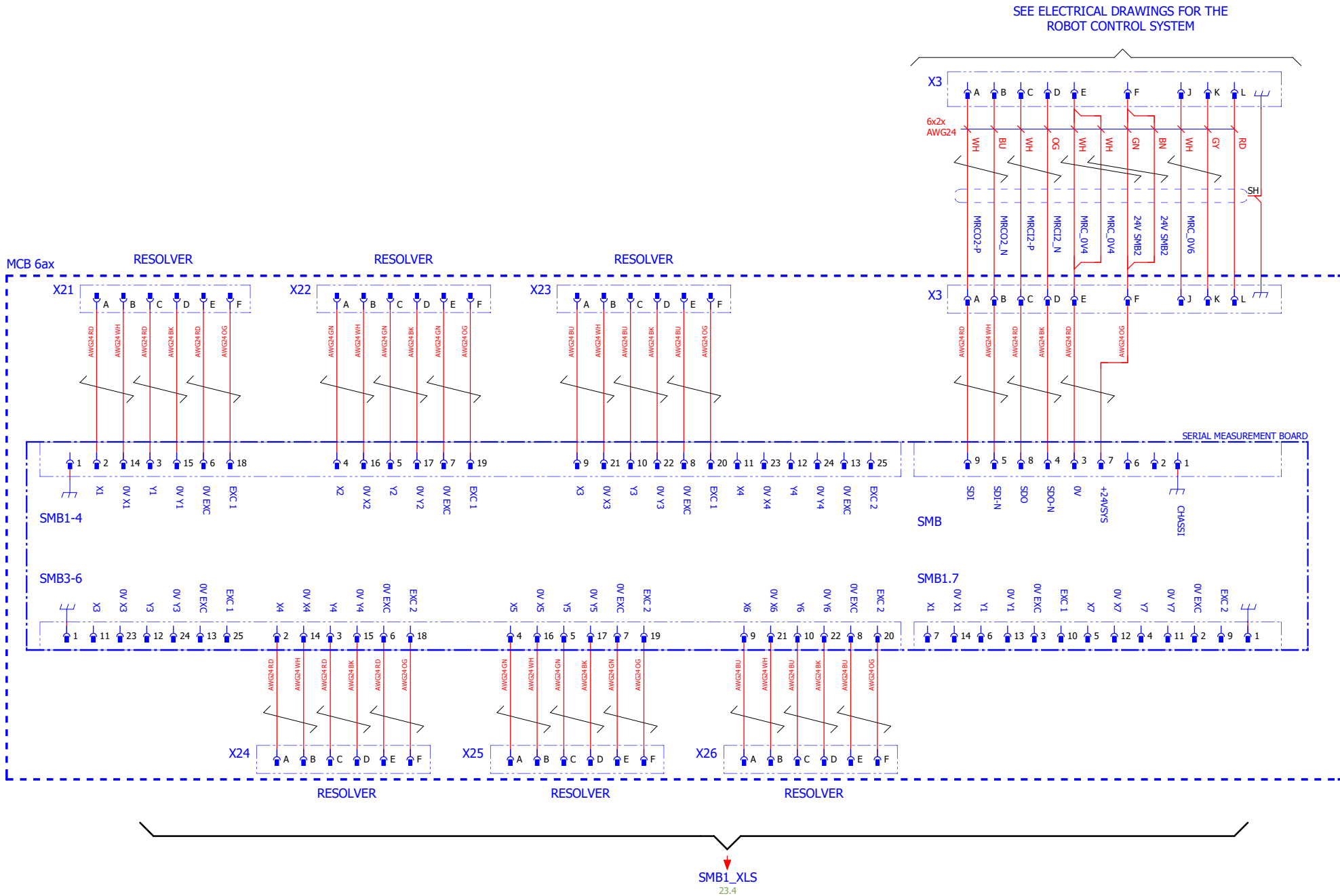

SEE ELECTRICAL DRAWINGS FOR THE ROBOT CONTROL SYSTEM

SMB1\_XLS  
23.4

Responsible Department: RARO/RD	Design by: Yan Zhang
Prepare by, Date: Yan Zhang 20240131	Approve by, Date: Fabrice Legeleux 202403

IRT 710 & OmniCore V-line  
Replacement of Replaced by



MOTOR RESOLVER, TRANSFER  
CARRIAGE SMB 1(6Axes)

Status: Approved  
Document no. 3HAC091443-001

Rev.Ind	Page 22
	Total Page 37

SMB1\_XLS  
22.5

SMB2\_XLS

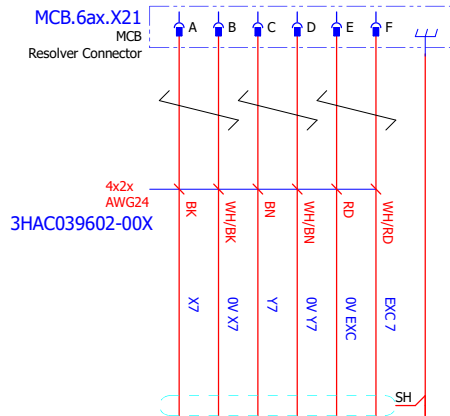

Carriage 1  
Motor Resolver

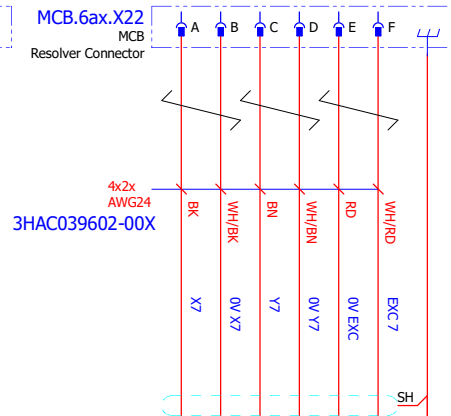

Carriage 2  
Motor Resolver  
(Option)

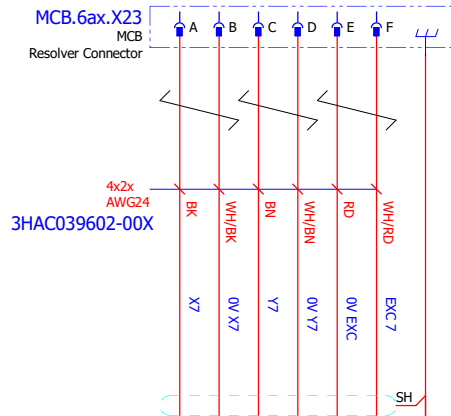

Carriage 3  
Motor Resolver  
(Option)

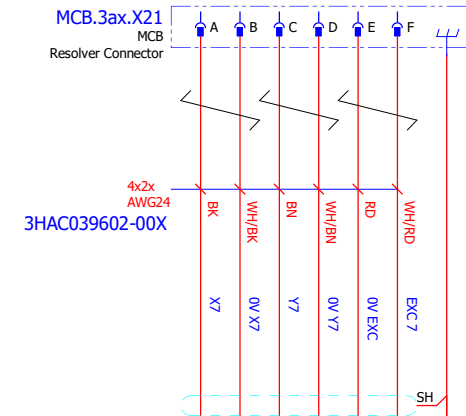

Carriage 4  
Motor Resolver  
(Option)





We reserve all rights in this document and in the information contained therein. Reproduction, use or disclosure to third parties without express authority is strictly forbidden. Copyright ABB

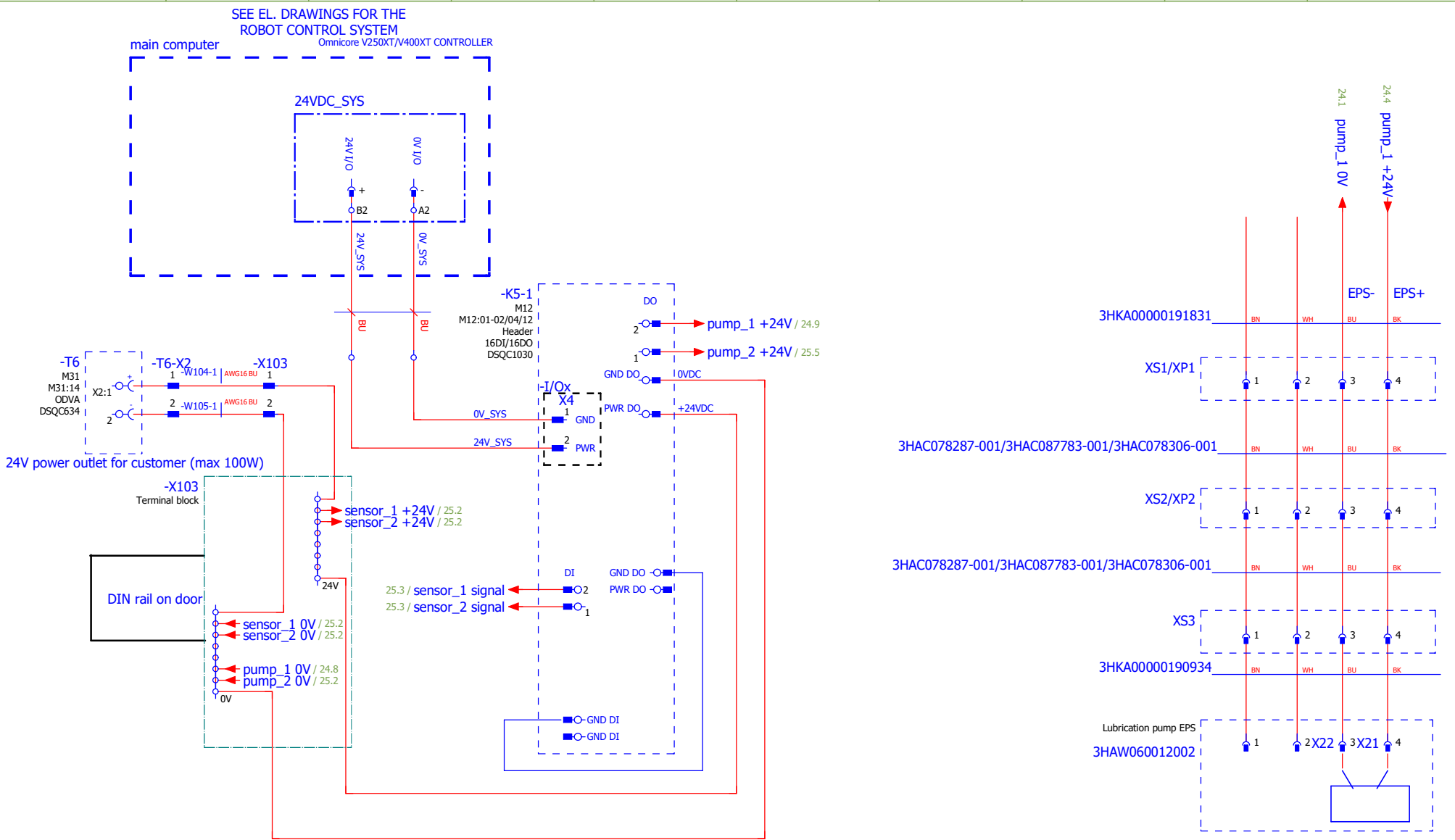

We reserve all rights in this document and in the information contained therein. Reproduction, use or disclosure to third parties without express authority is strictly forbidden. Copyright ABB

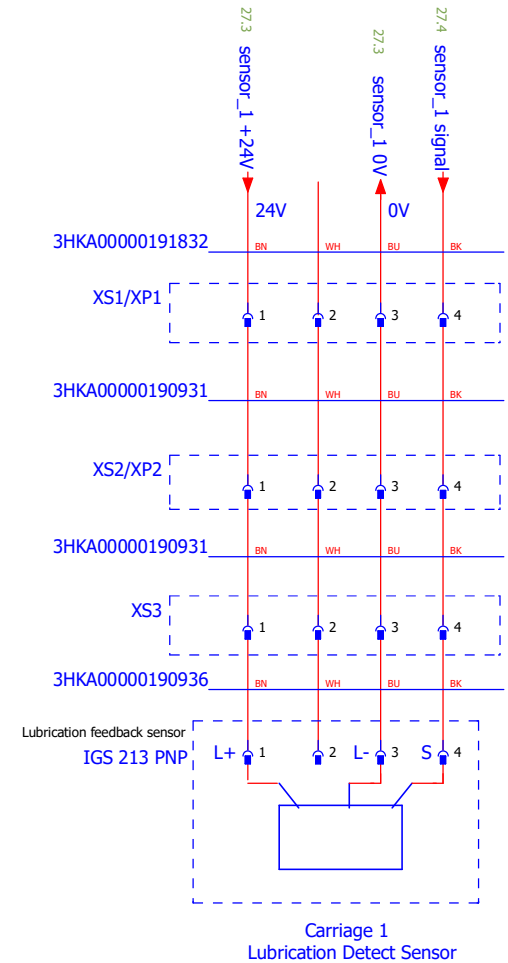
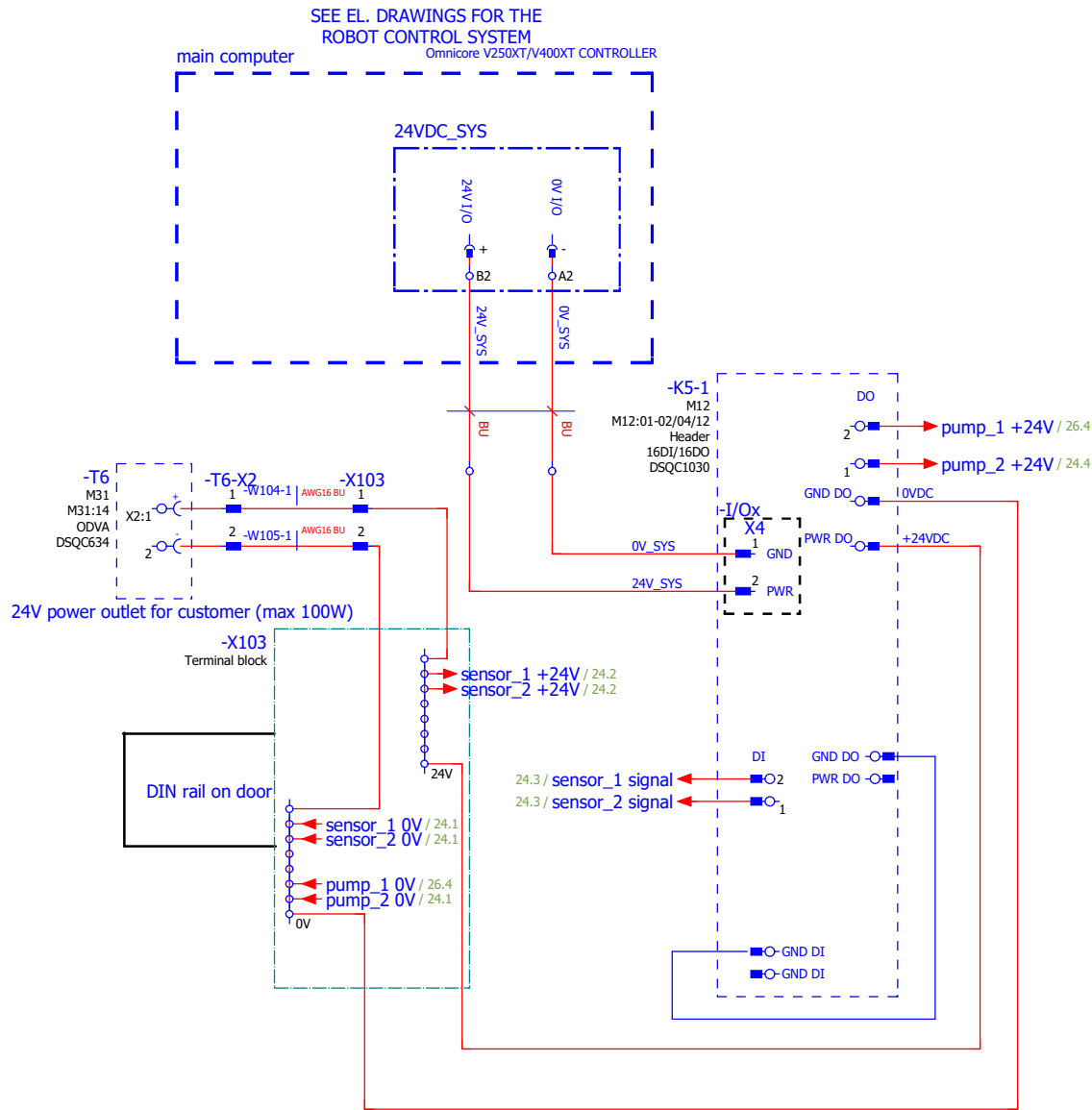

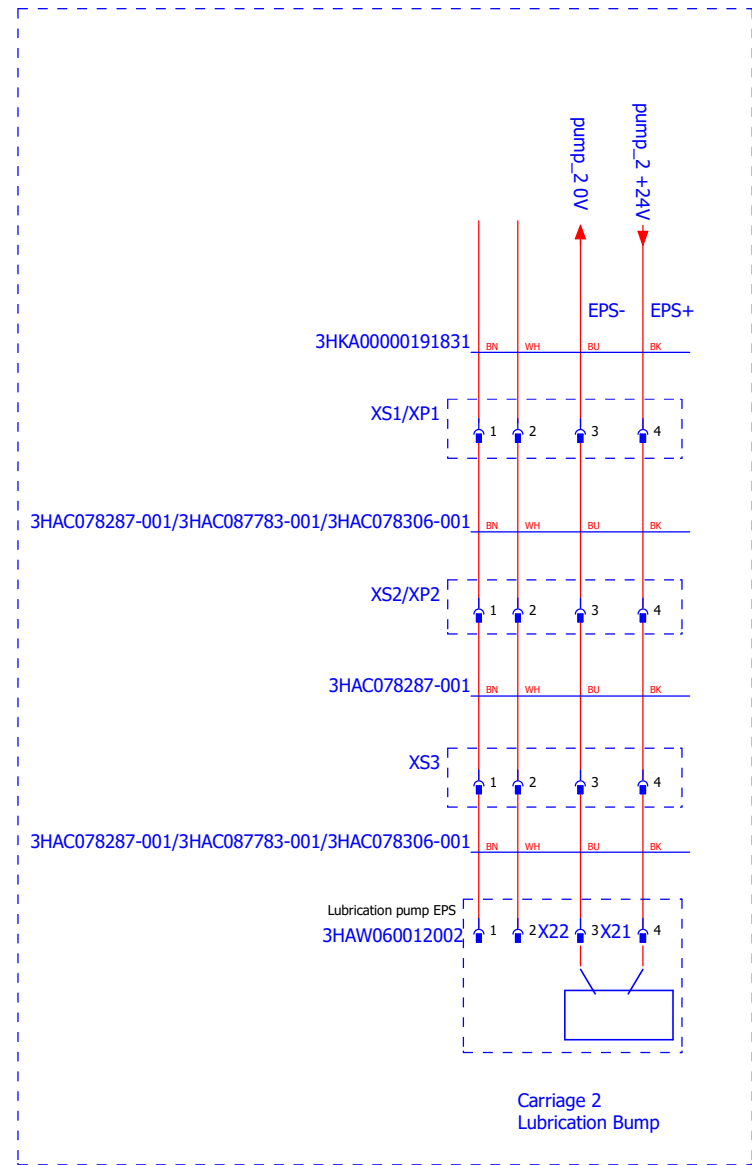
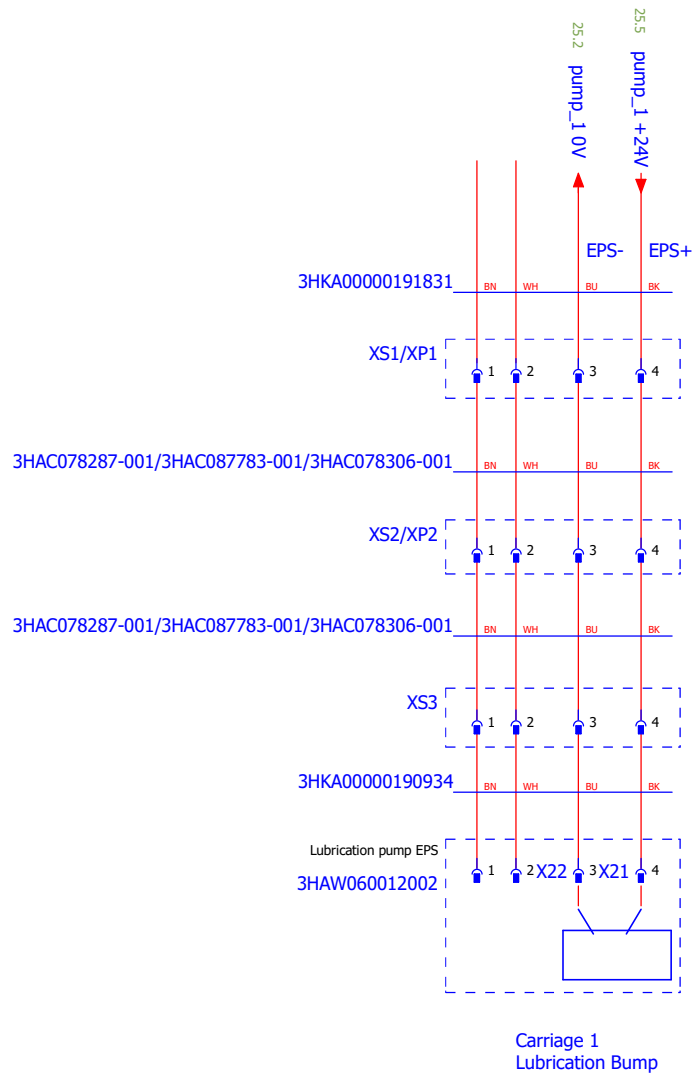

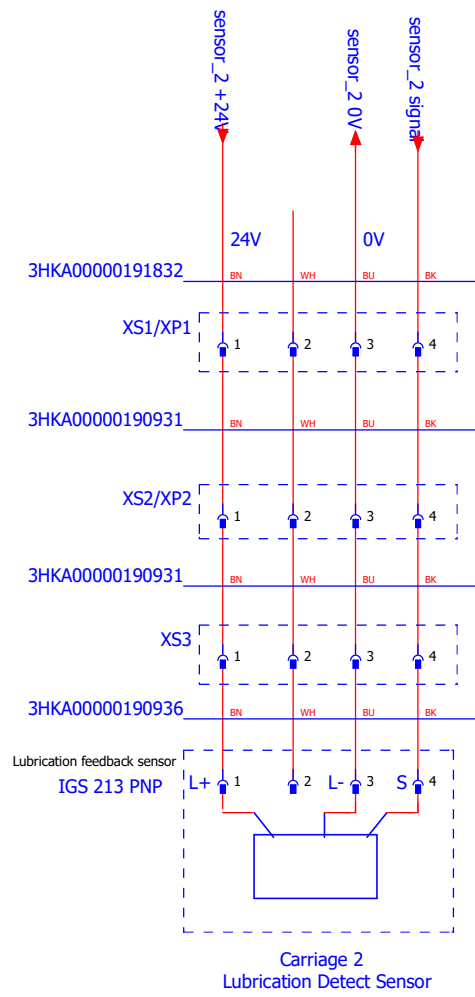
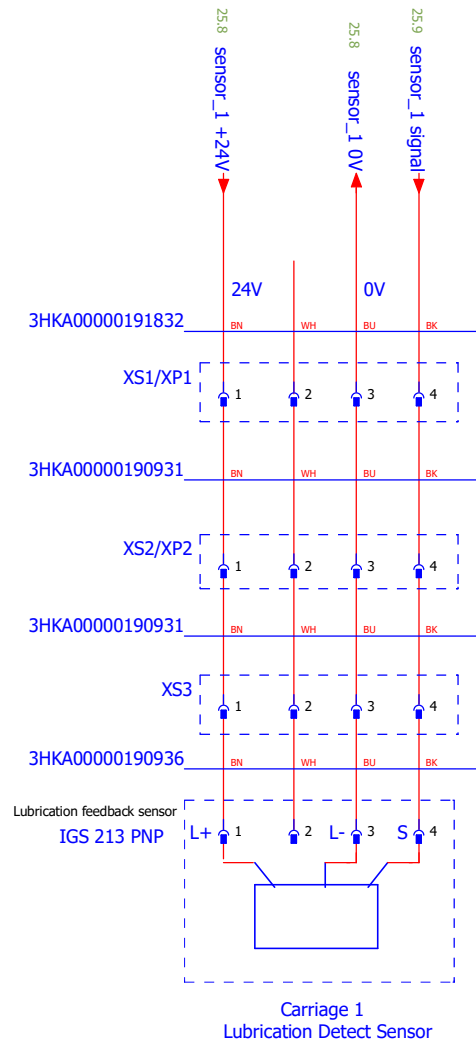

Responsible Department: RARO/RD	Design by: Yan Zhang
Prepare by, Date: Yan Zhang 20240131	Approve by, Date: Fabrice Legeleux 202403

IRT 710 & OmniCore V-line	Replacement of	Replaced by
---------------------------	----------------	-------------



OPTION LUBRICATION FEEDBACK  
TRANSFER CARRIAGE

Status: Approved  
Document no. 3HAC091443-001

Rev.Ind	Page 27
	Total Page 37

We reserve all rights in this document and in the information contained therein. Reproduction, use or disclosure to third parties without express authority is strictly forbidden. Copyright ABB

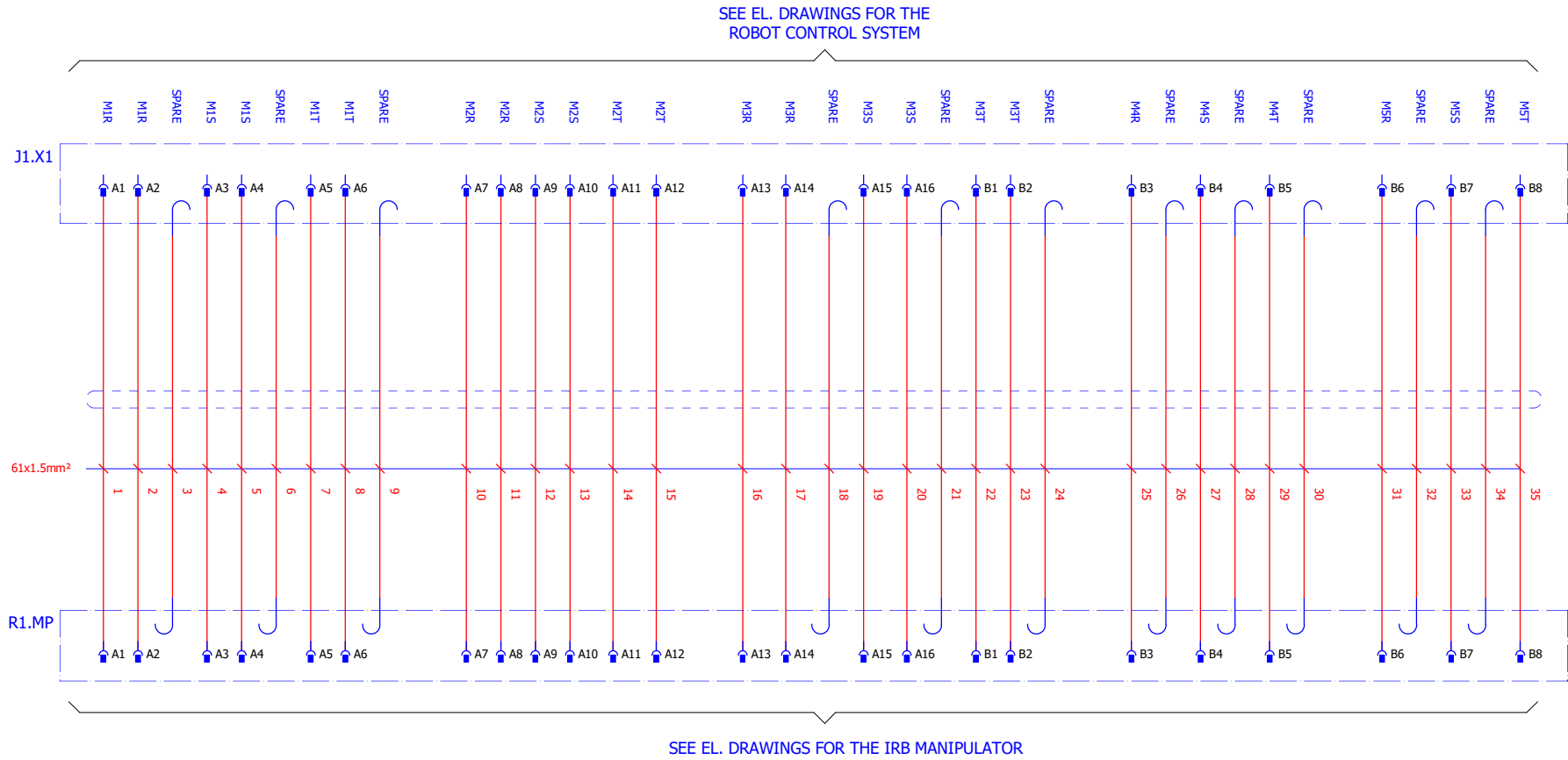

Responsible Department: RARO/RD	Design by: Yan Zhang
Prepare by, Date: Yan Zhang 20240131	Approve by, Date: Fabrice Legeleux 202403

IRT 710 & OmniCore V-line	Replacement of	Replaced by
---------------------------	----------------	-------------



MOTOR CABLE, IRB4400

Status: **Approved**  
Document no. 3HAC091443-001

Rev.Ind	Page 28
	Total Page 37

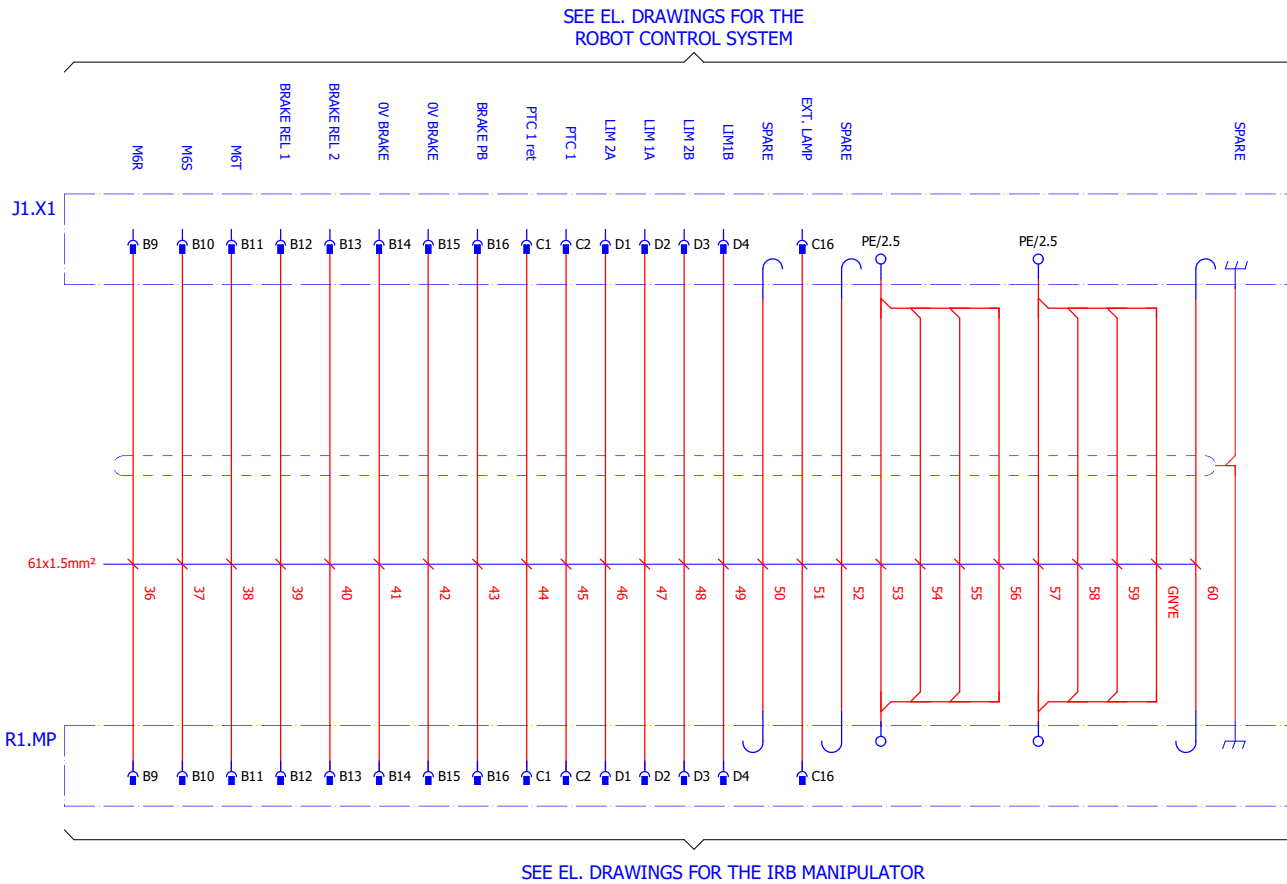

Responsible Department: RARO/RD	Design by: Yan Zhang
Prepare by, Date: Yan Zhang 20240131	Approve by, Date: Fabrice Legeleux 202403

IRT 710 & OmniCore V-line
Replacement of
Replaced by



MOTOR CABLE, IRB4400
----------------------

Status: Approved	=
Document no. 3HAC091443-001	+

Rev.Ind	Page 29
	Total Page 37

SEE EL. DRAWINGS FOR THE  
ROBOT CONTROL SYSTEM

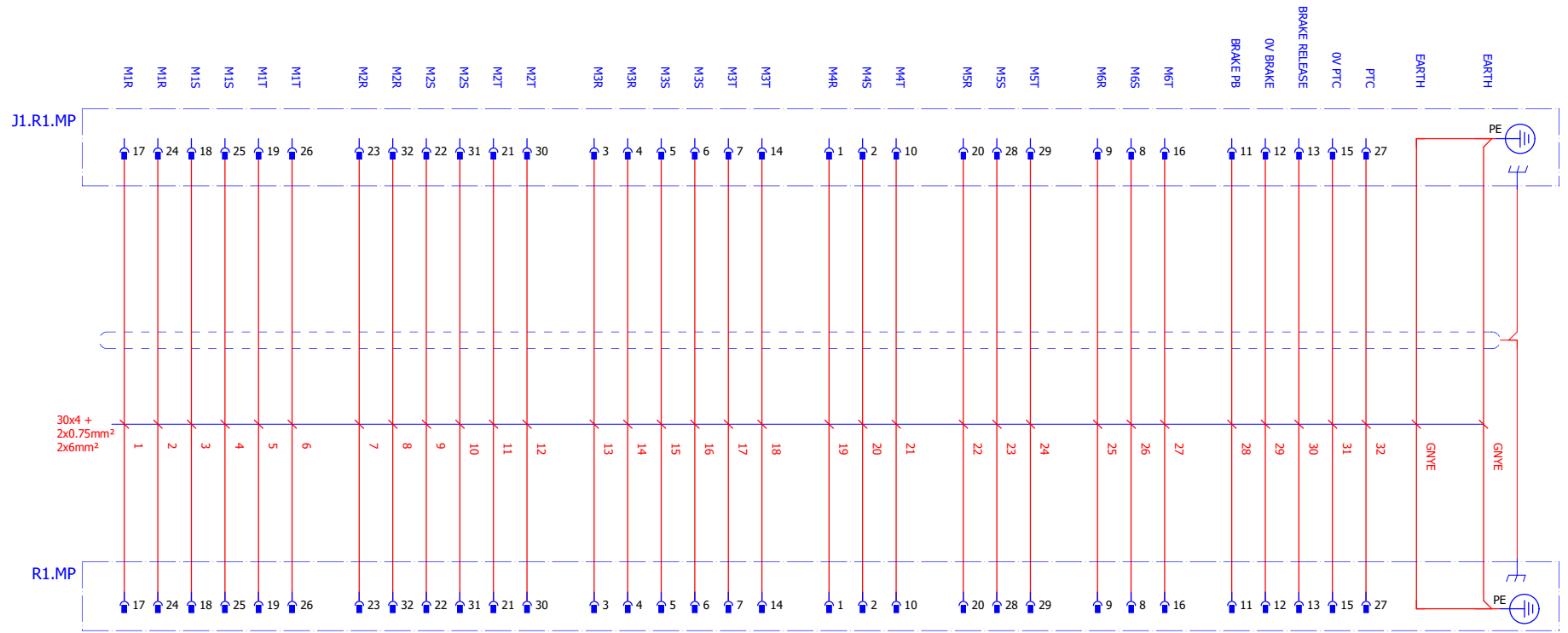

SEE EL. DRAWINGS FOR THE  
IRB MANIPULATOR

Responsible Department: RARO/RD		Design by: Yan Zhang		IRT 710 & OmniCore V-line		MOTOR CABLE, IRB460/760/4400/4600/6xx0/7600		Status: Approved		=	
Prepare by, Date: Yan Zhang 20240131		Approve by, Date: Fabrice Legeleux 202403		Replacement of		Replaced by		Document no. 3HAC091443-001		+	
								Rev.Ind		Page 30	
										Total Page 37	

SEE EL. DRAWINGS FOR THE  
ROBOT CONTROL SYSTEM

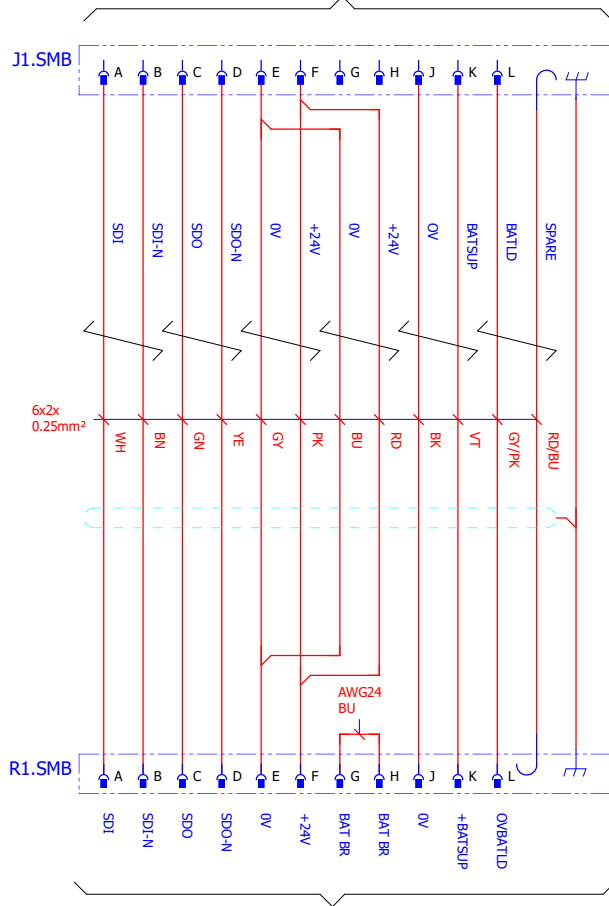

SEE EL. DWGS FOR THE  
IRB MANIPULATOR

Responsible Department: RARO/RD	Design by: Yan Zhang
Prepare by, Date: Yan Zhang 20240131	Approve by, Date: Fabrice Legeleux 202403

IRT 710 & OmniCore V-line	Replacement of	Replaced by
---------------------------	----------------	-------------



RESOLVER CABLE, IRB460/760/4600/6xx0/7600
--

Status: Approved	=
Document no. 3HAC091443-001	+

Rev.Ind	Page 31
	Total Page 37



We reserve all rights in this document and in the information contained therein. Reproduction, use or disclosure to third parties without express authority is strictly forbidden. Copyright ABB

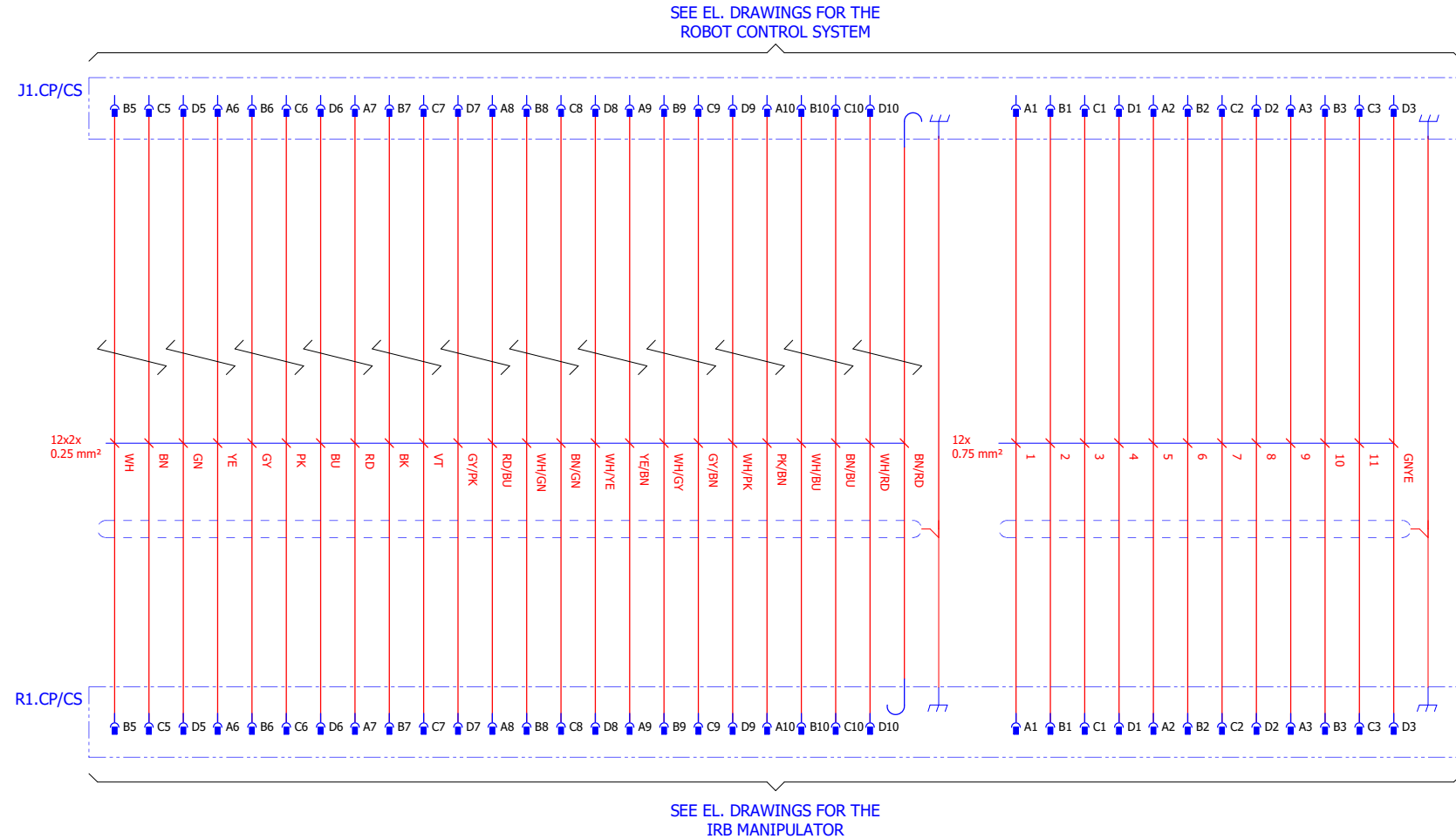

Responsible Department: RARO/RD Prepare by, Date: Yan Zhang 20240131	Design by: Yan Zhang Approve by, Date: Fabrice Legeleux 202403	IRT 710 & OmniCore V-line Replacement of	<div style="text-align: center;"> </div> OPTION CUSTOMER POWER/SIGNAL, IRB4400	Status: <b>Approved</b> Document no. <b>3HAC091443-001</b>	= +	Rev.Ind Page 32 Total Page 37
---	---	---	---	---	--------	-------------------------------------

We reserve all rights in this document and in the information contained therein. Reproduction, use or disclosure to third parties without express authority is strictly forbidden. Copyright ABB

SEE EL. DRAWINGS FOR THE  
ROBOT CONTROL SYSTEM

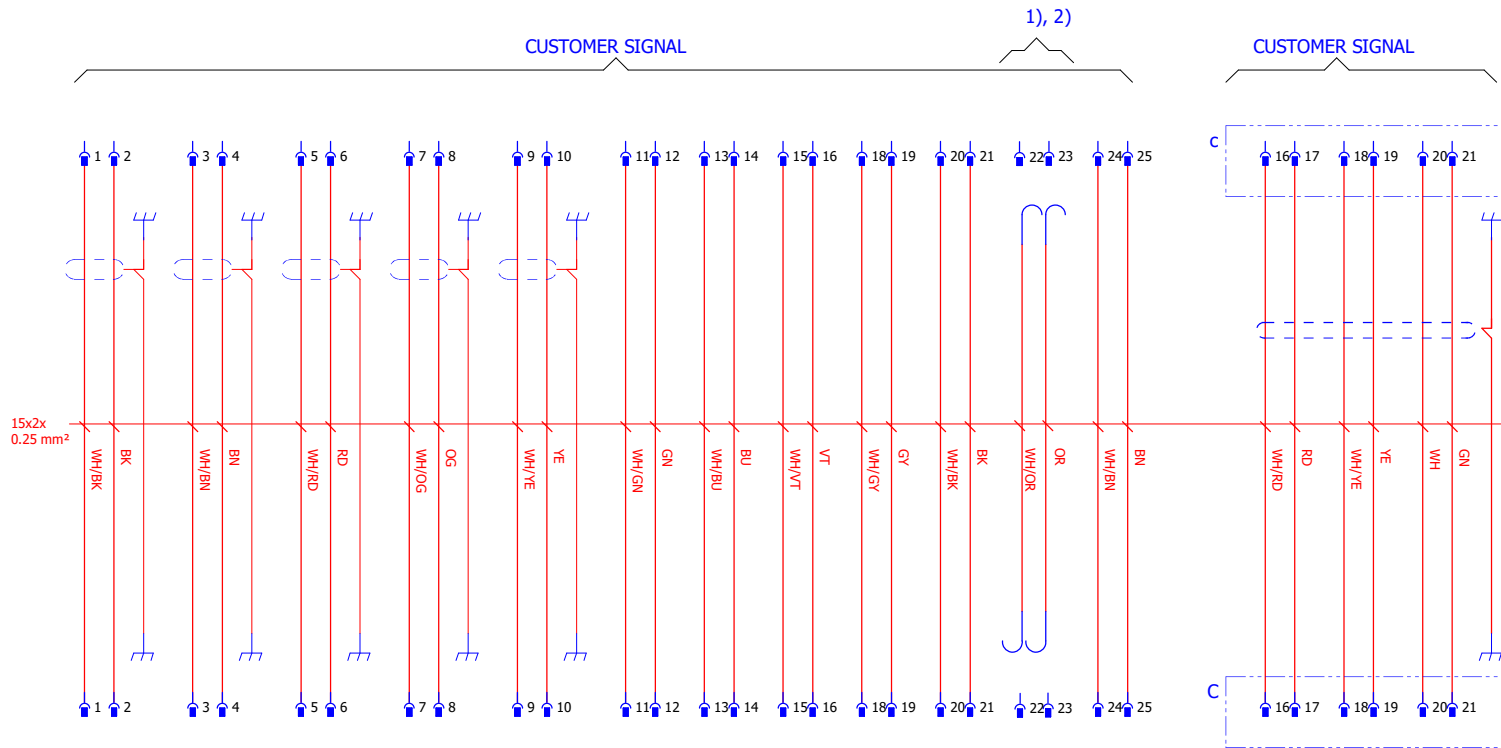

SEE EL. DRAWINGS FOR THE  
IRB MANIPULATOR

Responsible Department: RARO/RD	Design by: Yan Zhang
Prepare by, Date: Yan Zhang 20240131	Approve by, Date: Fabrice Legeleux 202403

IRT 710 & OmniCore V-line	Replacement of	Replaced by
---------------------------	----------------	-------------



OPTION CUSTOMER POWER/SIGNAL,  
IRB460/760/4600/6xx0/7600

Status: **Approved**  
Document no. **3HAC091443-001**

Rev.Ind	Page 33
	Total Page 37

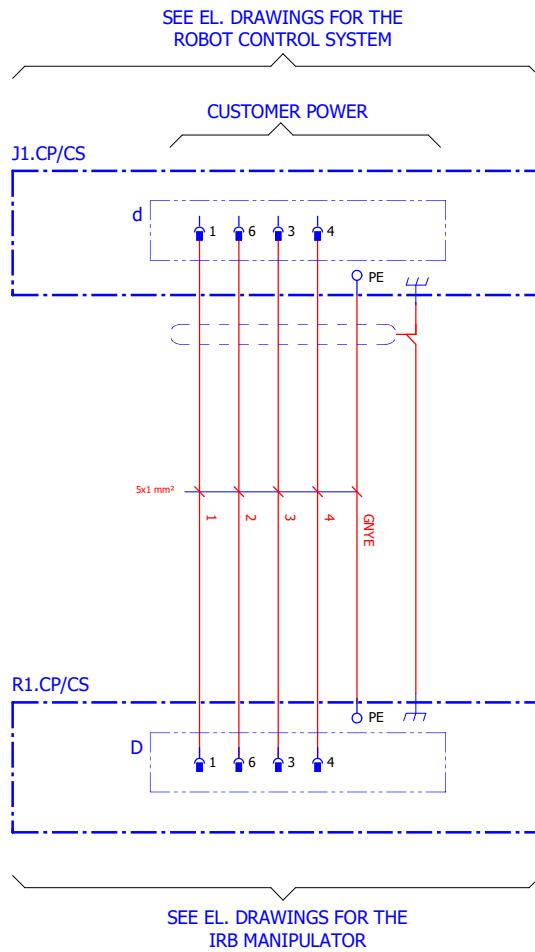

Responsible Department:	RARO/RD	Design by:	Yan Zhang
Prepare by,Date:	Yan Zhang 20240131	Approve by,Date:	Fabrice Legeleux 202403

IRT 710 & OmniCore V-line	
Replacement of	Replaced by



OPTION CUSTOMER POWER/SIGNAL  
PARALLEL, IRB460/760/4600/6xx0/7600

Status:  
**Approved**  
Document no.  
**3HAC091443-001**

=	Rev.Ind	Page
+		34
		Total Page
		37

SEE EL. DRAWINGS FOR THE  
ROBOT CONTROL SYSTEM

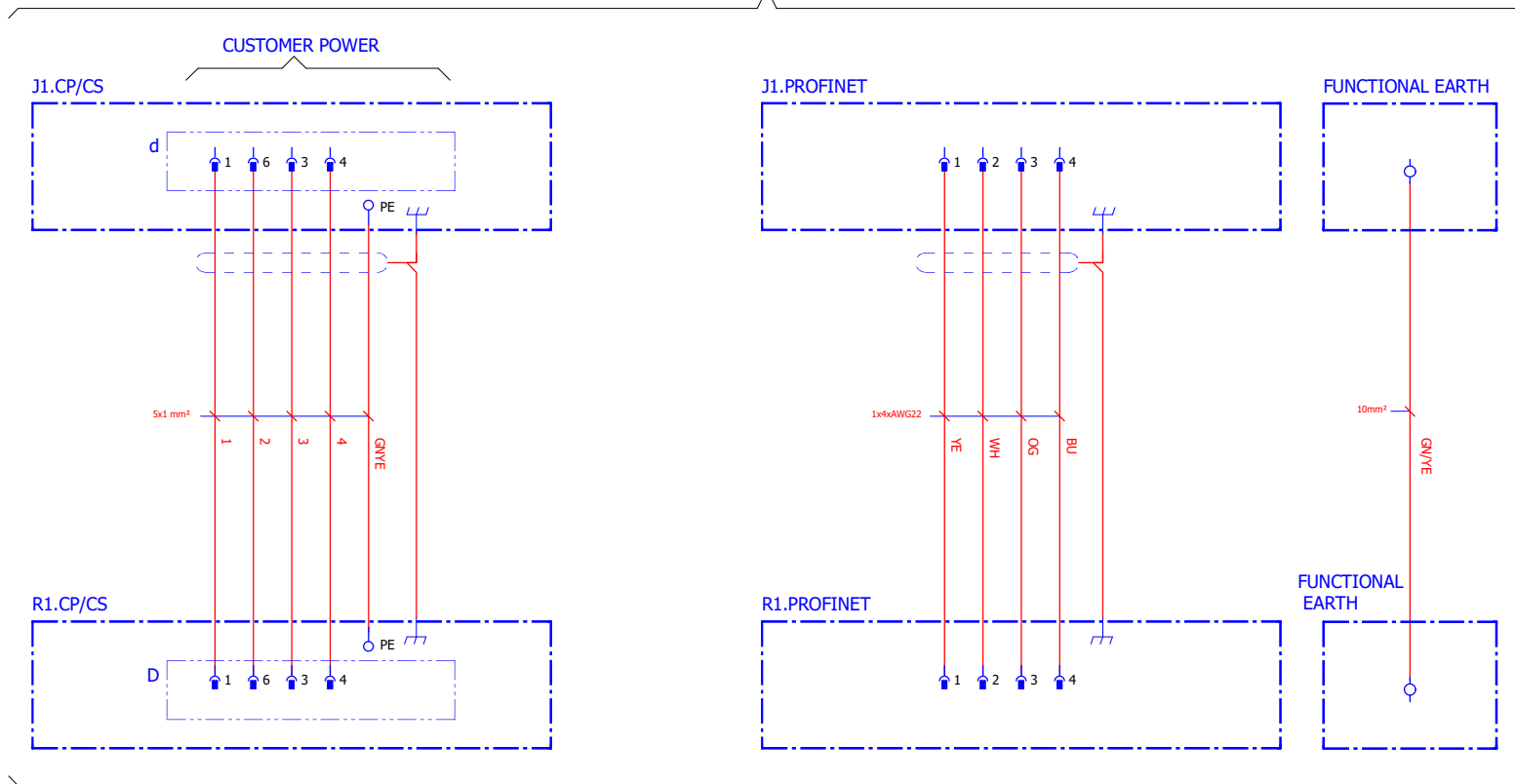

SEE EL. DRAWINGS FOR THE  
IRB MANIPULATOR

Responsible Department: RARO/RD		Design by: Yan Zhang		IRT 710 & OmniCore V-line		Status: Approved		=	
Prepare by, Date: Yan Zhang 20240131		Approve by, Date: Fabrice Legeleux 202403		Replacement of		PROFINET, IRB460/760/4600/6xx0/7600		+	
				Replaced by		Document no. 3HAC091443-001		Rev.Ind	
								Page 35	
								Total Page 37	



We reserve all rights in this document and in the information contained therein. Reproduction, use or disclosure to third parties without express authority is strictly forbidden. Copyright ABB

SEE EL. DRAWINGS FOR THE  
ROBOT CONTROL SYSTEM

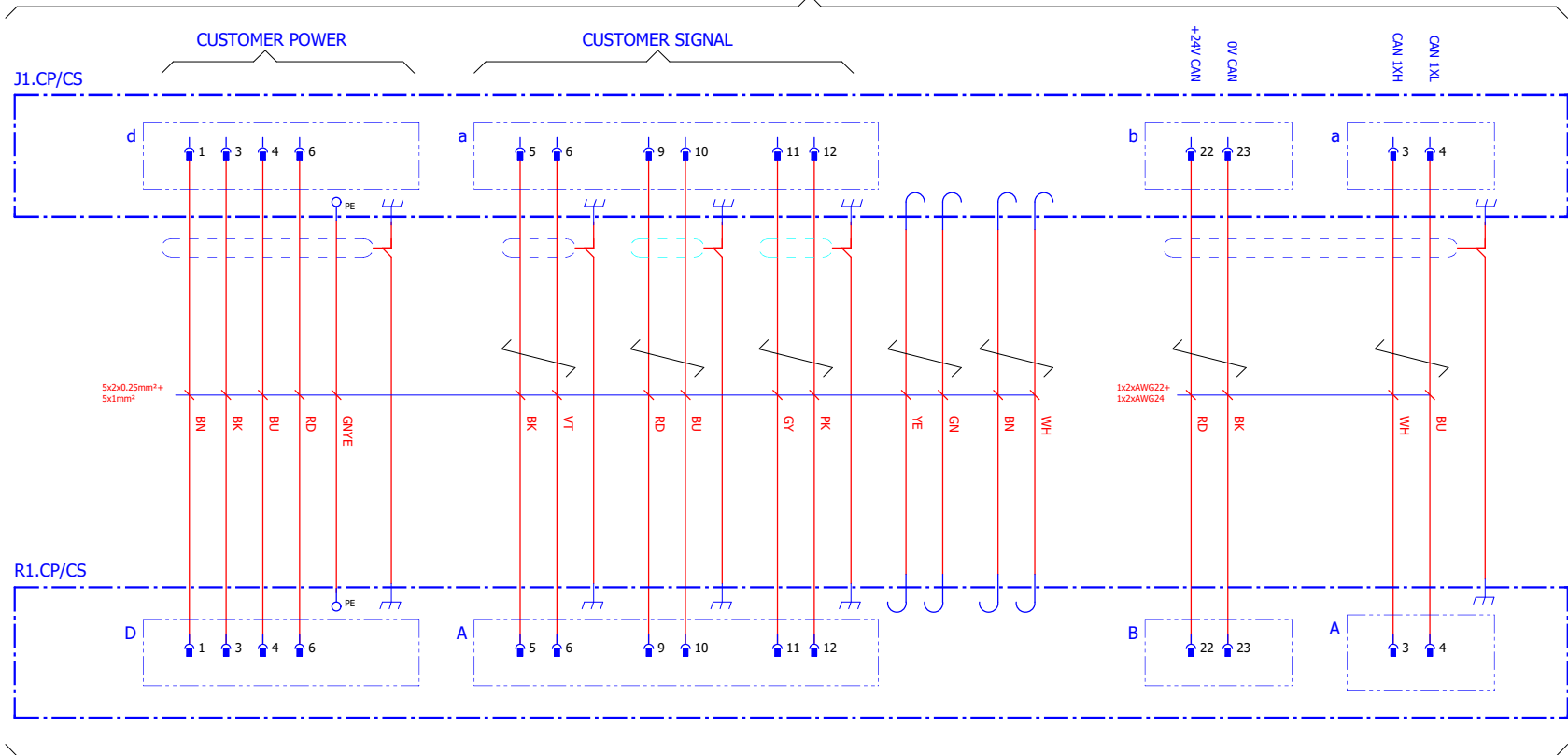

SEE EL. DRAWINGS FOR THE  
IRB MANIPULATOR

Responsible Department:	RARO/RD	Design by:	Yan Zhang
Prepare by, Date:	Yan Zhang 20240131	Approve by, Date:	Fabrice Legeleux 20240314

IRT 710 & OmniCore V-line	Replacement of	Replaced by
---------------------------	----------------	-------------



OPTION CUSTOMER POWER/SIGNAL  
DEVICENET,  
IRB460/760/4600/6xx0/7600

Status:  
**Approved**  
Document no.  
**3HAC091443-001**

Rev.Ind	Page
+	36
	Total Page
	37